

THE APOLLO INTELLIGENT METER SERIES



MODEL IMP INSTRUCTION MANUAL

INTRODUCTION

The Intelligent Meter for Process Inputs (IMP) is another unit in our multi-purpose series of industrial control products that is field-programmable to solve multiple applications. This series of products is built around the concept that the end user has the capability to program different personalities and functions into the unit in order to adapt to different indication and control requirements.

The Intelligent Process Meter which you have purchased has the same high quality workmanship and advanced technological capabilities that have made Red Lion Controls the leader in today's industrial market.

Red Lion Controls has a complete line of industrial indication and control equipment, and we look forward to being of service to you now and in the future.



**UL Recognized Component,
File #E186643**



CAUTION: Read complete instructions prior to installation and operation of the unit.



CAUTION: Risk of electric shock.

TABLE OF CONTENTS

I. SAFETY INFORMATION	1
II. GENERAL DESCRIPTION	2-3
A) Theory of Operation	2
B) Block Diagram	3
III. PROGRAMMING AND OPERATING THE IMP	4-23
A) Programming the IMP	4-5
B) Program Modules #1 thru #9	6-19
C) Operating the IMP (Quick Programming)	20
D) Factory Configuration	21
E) Programming Example	22
F) Pressure Monitoring Example	23
IV. EXCITATION (Optional)	24
V. TOTALIZER/LINEARIZER/PEAK/VALLEY/TARE (Optional)	24-28
A) Totalizer Example	24
B) Linearizer Example	25
C) Peak/Valley/Tare	27
VI. ALARMS (Optional)	28
VII. 20 mA CURRENT LOOP SERIAL COMMUNICATIONS (Optional)	29-34
A) General Description	29
B) Communication Format	29
C) Sending Commands to the IMP	30-31
D) Receiving Data from the IMP	32
E) Current Loop Installation	34
F) Serial Terminal Descriptions	34
G) Serial Communication Examples	34-35
VIII. RE-TRANSMITTED ANALOG OUTPUT (Optional)	36-37
IX. APPENDIX “A” - INSTALLATION AND CONNECTIONS	38-41
X. APPENDIX “B” - SPECIFICATIONS AND DIMENSIONS	42-44
XI. APPENDIX “C” - LINEARIZER PROGRAM	45-46
XII. APPENDIX “D” - TROUBLESHOOTING GUIDE	47
XIII. APPENDIX “E” - PROGRAMMABLE FUNCTIONS	48-49
XIV. APPENDIX “F” - USERS PROGRAMMING VALUES CHART	50-51
XV. APPENDIX “G” - ORDERING INFORMATION	52

SAFETY INFORMATION

SAFETY SUMMARY

All safety related regulations, local codes and instructions that appear in the manual or on equipment must be observed to ensure personal safety and to prevent damage to either the instrument or equipment connected to it. If provided by the equipment may be impaired.

Do not use the IMP to directly command motors valves, or other actuators not equipped with safeguards. To do so, can be potentially harmful to persons or equipment in the event of a fault to the unit.

DEFINITION OF TERMS

INSTALLATION CATEGORY (overvoltage category) I:

Signal level, special equipment or parts of equipment, telecommunication, electronic, etc. with smaller transient overvoltages than Installation Category (overvoltage category) II.

INSTALLATION CATEGORY (overvoltage category) II:

Local level, appliances, portable equipment, etc. with smaller transient overvoltages than Installation Category (overvoltage category) III.

GENERAL DESCRIPTION

The Apollo Intelligent Meter for Process Inputs (IMP) accepts standard process signals and precisely scales them into engineering units with high resolution. One model covers any current range within 0 to 50 mA DC. A full 6-digit display accommodates nearly any engineering units and holds large totalization values. State-of-the-art digital circuitry virtually eliminates errors due to drift. A full complement of option packages is available to fulfill many process applications.

The indicator features a choice of two different scaling procedures which greatly simplify initial set-up. English-style display prompts and front panel buttons aid the operator through set-up and operation. A front panel lock-out menu protects set-up data and operation modes from unauthorized personnel. Programmable digital filtering enhances the stability of the reading. Programmable remote input "E1-CON" pin can be utilized to control a variety of functions, such as totalizing, alarm control, display hold or tare operations. All set-up data is stored in E²PROM, which will hold data for a minimum of 10 years without power.

An optional integrator (*totalizer*)/linearizer can be used to totalize or integrate signals up to a maximum display value of 999,999. It features independent scaling and a low signal cut-out to suit a variety of signal integration applications. Additionally, nine segments and offsets can easily be programmed with this option to linearize transducers with non-linear outputs, such as square law devices. Programmable remote input "E2-CON" pin is included with the option and can be utilized to control a variety of functions, such as totalizing, alarm control, display hold or tare operations, simultaneously with "E1-CON" pin. Peak/valley (*max/min*) reading memory, and a signal re-zeroing (*tare*) function are included with this option and they are easily recalled and controlled by either the front panel or a remote input. All readings are retained at power-down.

Optional dual relays with parallel solid state outputs are fully programmable to operate in a wide variety of modes to suit many control or alarm applications.

Optional 20 mA loop, bi-directional serial communications provides computer and printer interfacing to extend the capabilities of the indicator. More than one unit can be connected in the loop with other RLC products which have serial communications capabilities.

An optional 4 to 20 mA or 0 to 10 VDC re-transmitted analog output can be scaled by the user to interface with a host of recorders, indicators and controllers. The type of analog output is determined by the model ordered. (See Ordering Information for available models.) The indicator has several built-in diagnostic functions to alert operators of most malfunctions. Extensive testing of noise

interference mechanisms and full burn-in make the indicator extremely reliable in industrial environments. The die-cast front bezel meets NEMA 4/IP65 requirements for washdown applications, when properly installed. Plug-in style terminal blocks simplify installation and wiring change-outs.

THEORY OF OPERATION

The IMP employs a microprocessor to perform the A/D conversion on the input signal via a voltage-to-frequency converter. It digitally scales the result, corrects for meter drift which may be present and then displays the result in a 6-digit display (*5 for input, 6 for totalizer*). The inputs are filtered to enhance the stability of the display. A non-volatile E²PROM memory device provides permanent data retention for operating variables. The display consists of drivers and 6-digit solid-state LEDs. The alarm option employs opto-isolators to isolate the open collector devices from meter common. Operating in parallel, the relays are type Form-C and are rated at 5-amps. The serial communication option features a built-in 20 mA current source and complete opto-isolation. The analog option features a 12-bit DAC and provides an output signal that is digitally scaled. The re-transmitted output is isolated from meter common.

FIG. 1: BLOCK DIAGRAM

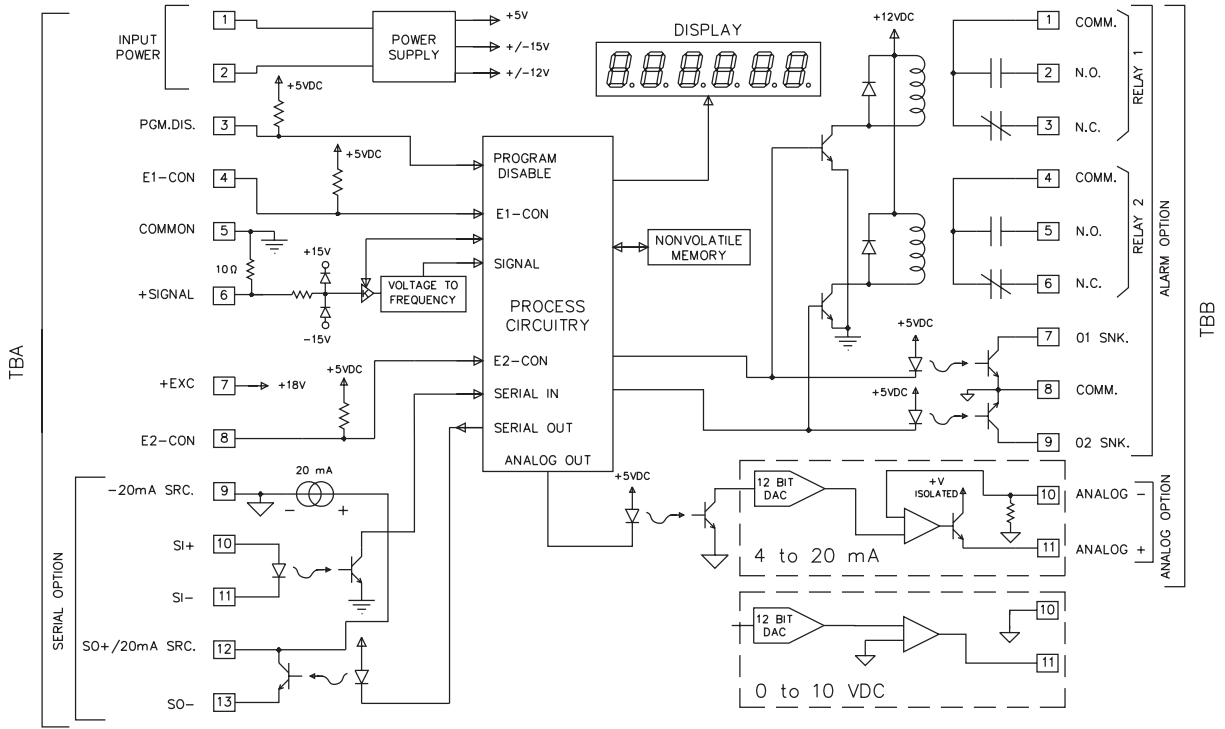

Note: Analog, Serial, and SNK output options are isolated from the signal common at a working voltage of 50 V. The commons should NOT be tied together.

PROGRAMMING THE IMP

Prior to installing and operating the indicator, it may be necessary to change the scaling to suit the display units particular to the application. Although the unit has been pre-programmed at the factory, the set-ups will generally have to be changed.

The indicator is unique in that two different scaling methods are available. The operator may choose the method that yields the easier and more accurate calibration. The two scaling procedures are similar in that the operator keys-in two display values and either keys-in or applies a signal value that corresponds to those display points (*see FIG. 2*). The location of the scaling points should be near the process end limits, for the best possible accuracy. Once these values are programmed (*coordinates on a graph*), the indicator calculates the slope and intercept of the signal/display graph automatically. No span/zero interaction occurs, making scaling a one-pass exercise. Basic scaling is complete after decimal point selection, unit rounding (*dummy zeros*) and digital filtering level selection. The following procedure should be followed to scale the indicator.

FIG. 2: SLOPE DIAGRAM

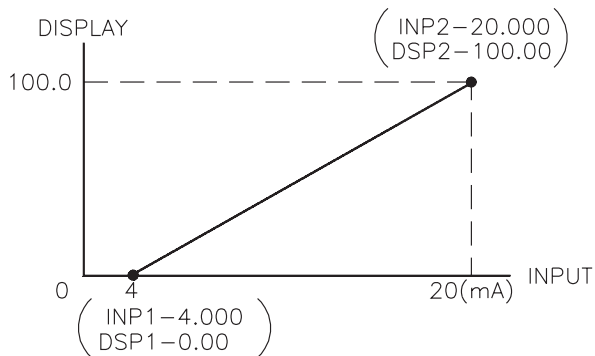

Before actually trying to program the indicator, it is advised to organize all the data for the programming steps to avoid any possible confusion and to read the programming procedure entirely before proceeding.

To set-up the indicator, connect AC power and signal wires as outlined in the connections section (*Appendix "A"*). Remove the jumper wire (*if installed*) from TBA #3 (*PGM. DIS.*). This will allow the operator to enter and modify all of the indicator's parameters. Press the front panel button labeled "P", momentarily. Briefly, the display will show "Pro" alternately flashing with "0". This is the indicator's programming mode. The programming mode is divided into sections, numbered 0-9, each of which can be individually accessed. The front panel "UP" and "DOWN" arrow buttons can be used to select one of these numbers and the "P" button used to enter the selected programming module. In all of the programming modules, "UP" and "DOWN" are used to either select from a list of choices or enter a value. The "P" button is used to save the new value and progress to the next step within a module (*Note: the new value takes effect when "P" is pressed*). Upon completion of a module, the indicator returns to the "Pro" <> "0" stage. Pressing the "P" button at this point causes the unit to display "End" after which the unit returns to the normal display mode. The following table explains the basic function of each step.

Note: <> This indicates that the display will alternate between the English prompt and the actual data.

DISPLAY

RESULT OF "P" BUTTON

- "Pro" <> "0" – Causes the indicator to return to normal display mode. Any changes to set-up data are permanently stored in the E²PROM.
- "Pro" <> "1" – Entry into this module allows the user to select the decimal point position, unit rounding and scaling by the method of applying the actual signal levels to the indicator that correspond to the programmed display values. Use this method when the transducer is connected to the process and the process can be brought to known levels (*ie. weight, flow, pressure, etc.*). Alternately, a precision signal source may be substituted to simulate the transducer. A second method is available in Pro 2.
- "Pro" <> "2" – Entry into this module allows the user to select the decimal point position and unit rounding, as in Pro 1, but the method of scaling differs in that the user keys in signal levels instead of applying signals to the indicator. Use this method when the signal transducer is pre-calibrated with known display values at known signal levels. An alternate method is available in Pro 1.
- "Pro" <> "3" – Module #3 allows the user to program what can be accessed from the front panel when the PGM. DIS. (*Program Disable, TBA #3*) pin is connected to common. This feature protects critical set-up data from accidental modification while allowing access to setpoints and other functions. The front panel lock-out menu (*quick programming*) includes setpoint modification, totalizer resetting, and peak/valley resetting.

Note: The term "Quick Programming" is used to refer to the ability to change the information that can be accessed from the front panel when the "PGM. DIS." terminal is connected to "COMM."

DISPLAY

RESULT OF "P" BUTTON

- "Pro" <> "4" – Module #4 programs the digital filtering level and the function of the remote input "E1-CON" pin (*TBA #4*), and, if the totalizer option is installed, the remote input "E2-CON" pin (*TBA #8*). The functions of the remote E1 and E2 pins are the same and include display hold, peak/valley modes, totalizer reset, alarm reset, signal re-zero (*tare*), reading synchronization or print request.
- "Pro" <> "5" – This module sets the time base, scale factor and low signal disable function for the optional totalizer/ integrator.
- "Pro" <> "6" – This module allows programming for the basic configuration of the alarm option. The programming includes HI/LO acting, tracking, alarm display, latched or auto-reset, assignment to either signal or integrator/totalizer, and alarm and hysteresis values.
- "Pro" <> "7" – Module #7 is the serial communication parameter programming. Baud rate, unit address, print request function and condensed prints are all programmable.
- "Pro" <> "8" – This module allows digital scaling of the retransmitted analog output. Display values that correspond to 4 mA or 0 VDC and 20 mA or 10 VDC are keyed-in to scale the output and it may be assigned to either the signal or the totalizer/integrator.
- "Pro" <> "9" – This module is the service operations sequence and is not normally accessed by the user. This step re-calibrates the basic input and is used to compensate for long-term drift. Execution of this module should be done by technicians with the proper equipment in accordance with a maintenance plan of yearly recalibrations. A code number entry step is used to protect from inadvertent entries. Also, there is a number of other access codes which provide test and set-up changes as an aid in troubleshooting.

PROGRAMMING MODULE #1 - SCALE BY SIGNAL LEVEL METHOD

PROGRAM DECIMAL POINT POSITION

Select the desired decimal point position of the scaled display by pressing either the “Up” or “Down” button.

Note: Whatever decimal point is selected will appear in succeeding programming steps. Also, the “P” button must be pressed after each step to enter the desired data and to proceed to the next step.

```
"dECPN" <> "0"  
"0.0"  
"0.00"  
"0.000"  
"0.0000"
```

PROGRAM ROUNDING INCREMENT AND RIGHT HAND DUMMY ZEROS

Rounding values other than one cause the scaled number to ‘round’ to the nearest rounding increment selected (*ie. rounding of ‘5’ causes ‘122’ to round to ‘120’ and ‘123’ to round to ‘125’*). If the process is inherently jittery, the display value may be rounded to a higher value than one. If the range of the process exceeds the required resolution, (*ex. 0-10,000 PSI, but only 10 PSI resolution required*), a rounding increment of 10 will effectively make the display more stable. This programming step is usually used in conjunction with programmable digital filtering (*Pro 4*) to help stabilize display readings. (*If display stability appears to be a problem and the sacrifice in display resolution is unacceptable, program higher levels of digital filtering or increase the level of process dampening.*) Rounding increments of 10, 20, 50, and 100 may also be used to add “dummy zeros” to the scaled readings, as desired.

```
"round" <> "1"  
"2"  
"5"  
"10"  
"20"  
"50"  
"100"
```

At this stage a choice of either return to “Pro 0” or continue with scaling of the display is offered.

```
“SCALE” <> “yES”  
“NO”
```

If “yES” was selected for the previous step, the scaling procedure is started. In order to scale the indicator, by either method, two signal level values and two display values that correspond to the signal values must be known. These four values are then used to complete the scaling operation. An example of a signal-display pair is listed below:

```
3.000 PSI @ 4.000 mA AND 15.000 PSI @ 20.000 mA  
Scaling point #1      Scaling point #2
```

Note that reverse acting indication can be accomplished by either reversing the two signal points or the display value points, but not both. If both are reversed, then forward (*normal*) acting indication will occur. In either case do not reverse the input wires to correct the action because the indicator is designed for positive signals only. With this scaling procedure, the display values are keyed in and signal values are applied to the indicator by either a signal simulator or the actual signal source.

KEY-IN DISPLAY VALUE FOR SCALING POINT #1

```
“dSP 1” <> “-99999” to “99999”      (ex. 3.000 PSI)
```

APPLY SIGNAL TO INDICATOR FOR SCALING POINT #1

The meter will indicate the actual amount of signal being applied to the input. However, the indicator still retains the previously applied value until “P” is pressed, at which time the new value is stored. Pressing either the “UP” or “DOWN” button causes the previous value to remain programmed in the unit.

```
“INP 1” <> “0-50”      (ex. 4.000)
```

KEY-IN DISPLAY VALUE FOR SCALING POINT #2

```
“dSP 2” <> “-99999” to “99999”      (ex. 15.000 PSI)
```

APPLY SIGNAL TO INDICATOR FOR SCALING POINT #2

The meter will indicate the actual amount of signal being applied to the input. However, the indicator still retains the previous value until "P" is pressed, at which time the new value is stored. Pressing either the "UP" or "DOWN" button causes the previous value to remain programmed in the unit.

"INP 2" <> "0-50" (ex. 20.000)

At this stage, scaling is complete. The indicator will automatically calculate the slope and offset of the display units after completing "Pro 1". It is recommended that the scaling operation be verified by applying various signals and checking the displayed reading.

If the totalizer/linearizer option is installed, the indicator, instead of completing Module #1 and returning to "Pro 0", will be ready to accept more scaling points for multisegment linearization. The quantity and location of the linearization points should be chosen very carefully to best utilize the segments available. Refer to the section on linearization for a discussion on this matter.

PROGRAM NUMBER OF LINEAR SEGMENTS

This programming step loads in the number of linear segments desired for multisegment linearization. If just single slope scaling is all that is desired, input "1" for this step. If two segments are desired input "2", etc. You must have one more scaling point known than the number of segments selected (*ie. 1 segment = 2 points, 2 segments = 3 points, etc*). This step may be used to de-activate previously programmed segments where lower segments would override (*ex. changing "SEGt" from 5 to 3 causes slopes 4 & 5 to be replaced by an extension of slope 3*).

"SEGt" <> "1" - "9"

If "1" was selected, the indicator will return to "Pro 0" since scaling for the first segment was already completed. Otherwise, a choice of either returning to "Pro 0" or commencing with the multislope-linearization scaling is offered.

"SCALE" <> "yES"
"NO"

KEY-IN DISPLAY VALUE FOR POINT #3

If "YES" was selected, the display value for the third point is entered. Otherwise, the indicator returns to "Pro 0".

"dSP 3" <> "-99999" to "99999"

APPLY SIGNAL TO INDICATOR FOR POINT #3

The signal level value for point 3 is applied.

"INP 3" <> "0-50"

The sequence of entering display and signal values continues with "dSP 4" "INP 4", "dSP 5", etc. until the number programmed for "SEGt" is reached. Upon completion, the indicator is scaled to the multiple segments. It is recommended that the scaling be checked by applying signal values and verifying for correct display values.

Note: As the "UP" or "DOWN" button is continually held in, the display will progressively increment faster until the fourth most significant digit is changing at a rate of 1 number per second.

PROGRAMMING MODULE #2 - SCALE BY KEY-IN METHOD

PROGRAM DECIMAL POINT POSITION

Select the desired decimal point position of the scaled display by pressing either the “Up” or “Down” button.

Note: Whatever decimal point is selected will appear in succeeding programming steps. Also, the “P” button must be pressed after each step to enter the desired data and to proceed to the next step.

“dECPN” < > “0”
“0.0”
“0.00”
“0.000”
“0.0000”

PROGRAM ROUNDING INCREMENT AND RIGHT HAND DUMMY ZEROS

Rounding values other than one cause the scaled number to ‘round’ to the nearest rounding increment selected (*ie. rounding of ‘5’ causes ‘122’ to round to ‘120’ and ‘123’ to round to ‘125’*). If the process is inherently jittery, the display value may be rounded to a higher value than one. This will allow the display to be easier to read. If the range of the process exceeds the required resolution, (*ex. 0-10,000 PSI, but only 10 PSI resolution required*), a rounding increment of 10 will effectively make the display more stable. This programming step is usually used in conjunction with programmable digital filtering (*Pro 4*) to help stabilize display readings. (*If display stability appears to be a problem and the sacrifice in display resolution is unacceptable, program higher levels of digital filtering or increase the level of process dampening.*) Rounding increments of 10, 20, 50, and, 100 may also be used to add “dummy zeros” to the scaled readings, as desired.

“round” < > “1”
“2”
“5”
“10”
“20”
“50”
“100”

At this stage a choice of either return to “Pro 0” or continue with scaling of the display is offered.

“SCALE” < > “YES”
“NO”

If “YES” was selected for the previous step, the scaling procedure is started. In order to scale the indicator, two signal level values and two display values that correspond to the signal values must be known. These four values are directly entered into the indicator. An example of a signal-display pair is listed below:

3.000 PSI @ 4.000 mA AND 15.000 PSI @ 20.000 mA
Scaling point #1 Scaling point #2

Note that reverse acting indication can be accomplished by either reversing the two signal points or the display value points, but not both. If both are reversed, then forward (*normal*) acting indication will occur. In either case, do not reverse the input signal wires because the indicator was designed to accept positive signals only. With this scaling procedure, both the display values and signal values are keyed in.

KEY-IN DISPLAY VALUE FOR SCALING POINT #1

“dSP 1” < > “-99999” to “99999” (ex. 3.000 PSI)

KEY-IN SIGNAL VALUE FOR SCALING POINT #1

“INP 1” < > “0-50” (ex. 4.000)

KEY-IN DISPLAY VALUE FOR SCALING POINT #2

“dSP 2” < > “-99999” to “99999” (ex. 15.000 PSI)

KEY-IN SIGNAL VALUE FOR SCALING POINT #2

“INP 2” <> “0-50” (ex. 20.000)

At this point, scaling is complete. The indicator will automatically calculate the slope and offset of the display units. It is recommended that the scaling operation be verified by applying various signals and checking the displayed reading.

If the totalizer/linearizer option is installed, the indicator, instead of completing module #1 and returning to “Pro 0”, will be ready to accept more scaling points for multisegment linearization. The quantity and location of the linearization points should be chosen very carefully to best utilize the segments available. Refer to the section on linearization for a discussion on this matter.

PROGRAM NUMBER OF LINEAR SEGMENTS

This programming step loads in the number of linear segments desired for multisegment linearization. If just single slope scaling is all that is desired, program “1” for this step. If two segments are desired, program “2”, etc. You must have one more scaling point known than the number of segments selected (*ie. 1 segment = 2 points, 2 segments = 3 points, etc*). This step may also be used to de-activate previously programmed segments where lower segments would override (*ex. changing “SEGt” from 5 to 3 causes slopes 4 and 5 to be replaced by an extension of slope 3*).

“SEGt” <> “1” - “9”

If “1” was selected, the indicator will return to “Pro 0” since scaling for the first slope was already completed. Otherwise, a choice of either returning to “Pro 0” or commencing with the multislope-linearization scaling is offered.

“SCALE” <> “yES”
“NO”

If “yes” was selected, the display value for the third point is entered. Otherwise, the indicator returns to “Pro 0”.

KEY-IN DISPLAY VALUE FOR SCALING POINT #3

“dSP 3” <> “-.99999” to “99999”

KEY-IN INPUT VALUE FOR SCALING POINT #3

“INP 3” <> “0-50”

The sequence of entering display and signal values continues with “dSP 4” “INP 4”, “dSP 5”, etc. until the number programmed for “SEGt” is reached. Upon completion, the indicator is scaled to the multiple segments. It is recommended that the scaling be checked by exiting the programming mode and applying signal values and verifying for correct display values.

Note: As the “UP” or “DOWN” button is continually held in, the display will progressively increment faster until the fourth most significant digit is changing at a rate of 1 number per second.

PROGRAMMING MODULE #3 - PROGRAM FUNCTIONS ACCESSIBLE W/ FRONT PANEL LOCKOUT

This programming module programs what is accessible through the front panel when the PGM. DIS. pin is connected to common (COMM.).

Note: The term "Quick Programming" is used to refer to the ability to change the information that can be accessed from the front panel when the "PGM. DIS." terminal is connected to "COMM."

DISPLAY ALARM VALUES

If the alarm option is installed, this selects whether the alarm values will or will not be displayed.

"dSP AL" <> "yES" or "NO"

ENTER ALARM VALUES †

If "YES" was selected for display alarm values, this will select if alarm values may be modified from the front panel. If "NO" was selected for display alarm values, then this step will default to "NO" and will not be displayed for selection.

"Ent AL" <> "yES" or "NO"

DISPLAY HYSTERESIS VALUES †

If the alarm option is installed, this selects whether the hysteresis values will or will not be displayed.

"dSPHYS" <> "yES" or "NO"

ENTER HYSTERESIS VALUES †

If "YES" was selected for display hysteresis values, this selects whether hysteresis values may be modified from the front panel. If "NO" was selected for display hysteresis values, then this step will default to "NO" and will not be displayed for selection.

"EntHYS" <> "yES" or "NO"

† *Note: This sequence may be locked-out due to other programmed sequences.*

RESET LATCHED ALARMS

If the alarm option is installed and if either alarm is programmed to latch, this will select if a latched alarm(s) can be reset from the front panel.

"rSt AL" <> "yES" or "NO"

DISPLAY PEAK/VALLEY MEMORY BUFFER

If the totalizer/linearizer option is installed, this selects whether peak and valley buffers will be displayed.

"dSPbUF" <> "yES" or "NO"

RESET PEAK/VALLEY MEMORY BUFFER †

If "YES" was selected for the previous step, this selects whether the peak and valley buffers may be reset from the front panel. If "NO" was selected, then this step defaults to "NO" and will not be displayed for selection.

"rStbUF" <> "yES" or "NO"

SELECT DISPLAY *

If the totalizer/linearizer option is installed, this selects whether the display can be switched from input display to total display and from total display to input display.

Note: When "NO" is selected, whatever display (Input or total) is shown, will be the only display accessible.

"SEldSP" <> "yES" or "NO"

RESET TOTAL *

If the totalizer/linearizer option is installed, this selects whether the total can be reset from the front panel.

"rSttOt" <> "yES" or "NO"

**Note: This function operates independent of the state of the "PGM. DIS." Pin.*

RE-ZERO INPUT*

If the totalizer/linearizer option is installed, this selects whether the signal can be re-zeroed (*tared*) through the front panel.

“tArE” < > “yES” or “NO”

Note: The tare buffer can be cleared by “stepping” through “Pro 2”, using the P button or via serial transmission.

Depending on functions selected under Pro 3 and Pro 6, alarms, hysteresis, peak, and valley values can be monitored and/or changed when PGM. DIS. is tied to COMM. This provides a “QUICK PROGRAMMING” method for “*day to day*” process changes. (*See QUICK PROGRAMMING SECTION for more details.*)

**Note: This function operates independent of the state of the “PGM. DIS.” Pin.*

PROGRAMMING MODULE #4 - PROGRAM DIGITAL FILTER AND REMOTE INPUT

PROGRAM DIGITAL FILTERING

If the displayed process signal is difficult to read due to small process variations or noise, increased levels of filtering will help to stabilize the display. This programming step may be used in conjunction with display rounding programming (*Pro 1 & 2*) to help minimize this effect. The digital filter used is an “adaptive” filter. That is, the filter coefficients change dynamically according to the nature of the input signal. This feature simultaneously allows the filter to settle quickly for large input changes while providing a stable display reading for normal process variations. Because of the adaptive nature of the filter, it cannot be characterized in terms of a time constant. The following table lists the maximum settling time for a step input to within 99% of the final value.

Filter Value	Settling Time (99%)
“FILtEr” <> “0” - no digital filtering	1.5 sec.
“1” - normal filtering	2 sec.
“2” - increased filtering	6 sec.
“3” - maximum filtering	13 sec.

PROGRAM FUNCTION OF E1-CON & OPTIONAL E2-CON PIN

The functions of the remote input “E1-CON” pin (*TBA #4*) and, if the totalizer option is installed, the remote input “E2-CON” pin (*TBA #8*) are the same. Functions are activated, as described in the appropriate function, when connected to signal common (*TBA #5*). Whether a function is edge or level activated, it must be held low for a minimum of 20 msec in order for the function to occur. The remote input pins can be used simultaneously and with any combination of functions. When the pins are tied together and activated, E1-CON function is generally performed first.

- “E1-CON” <> “0” - A negative going edge re-zeros (*tares*) the input signal.
Note: The tare buffer can be cleared by “stepping” through “Pro 2”, using the P button or via serial transmission.
- “1” - A negative going edge resets the contents of the totalizer to zero. Totalization commences regardless of the state of the input.

“2” - A negative going edge resets the contents of the totalizer to zero and allows totalization as long as the input is low. If the input goes high, totalization is stopped and the contents are saved. This acts as a totalization enable control from time T1 to T2.

“3” - A low level allows totalization as long as the input is low. If the input goes high, totalization is stopped and the contents are saved. This acts as a totalization enable control from time T1 to T2.

“4” - A low level holds the display (*display hold*). While this input is low, the indicator continues to process the input signal and drive the alarms, totalizer, etc. with the actual signal. The contents of the totalizer are stored at the same time the input display is held.

Note: If display hold is activated and input value is requested via serial, the value on the display will be sent instead of the actual input value at that time.

“5” - A negative going edge resets both peak and valley buffers.

Note: After P/V is called up, a change will not appear on the display until the next time the P/V is called up.

“6” - A negative going edge resets only the peak buffer and the indicator enters a peak reading display mode as long as the input is low. If the input goes high, peak detection and indication are stopped and the last peak reading is retained.

“7” - A negative going edge resets only the valley buffer and the indicator enters a valley reading display mode as long as the input is low. If the input goes high, valley detection and indication are stopped and the last valley reading is retained.

- “8” - If the alarm option is installed, a negative going edge resets the latched alarm(s).
- “9” - If the alarm option is installed, a low level resets a latched or unlatched alarm into its inactive state. This provides manual override of alarms for system startup and other unusual events such as system testing.
- “10” - A negative going edge toggles the display between “*input*” and “*total*” (*from input to total, or vice versa*). No action is taken on the positive going edge.
- “11” - A negative going edge zeros (*tares*) the input signal and adds the value that was on the input display to the totalizer value. The time-base, scale factor and low signal cut-out in “*Module #5*” are in effect disabled, when this function is selected. Example: 25.0 pounds of one ingredient is loaded, input is tared to 0.0, totalizer = 25.0 pounds. 50.0 pounds of another ingredient are loaded, input is tared to 0.0, totalizer = 75.0 pounds. This acts as a batch totalization.
- “12” - Display hold with tare. A negative going edge tares (*zeros*) the input signal. Prior to the tare operation, the input signal is saved and held (*display hold*) as long as the remote input pin is low. On the positive edge the input display will show zero. If there is a change to the input signal while the remote input is low, the display will reflect (*show*) the change at the positive edge.
- “13” - Instrument reading synchronization. A low level disables all meter operations (*alarms, total, analog out, etc.*). A positive edge resets the start of the A/D conversion, to allow synchronization with external processes and controls. While this function is active, the other E-CON pin will be acknowledged.
- “14” - Print request. Transmits data according to the print options that have been selected in Program Module #7. If the low time exceeds 800 msec, a second print-out will occur.

“E2-CON” < >

If the totalizer option is installed, E2-CON has the same programmable functions as E1-CON.

PROGRAMMING MODULE #5 - PROGRAM TOTALIZER/INTEGRATOR

Programming for the totalizer/integrator consists of four programming steps: totalizer decimal point position, time base, scale factor and low signal disable. Note that the decimal point position of the totalizer can be independent of the decimal point position of the scaled input signal. The totalizer value will roll over and flash when the total exceeds, 999999 or -999999, indicating an overflow condition. Reverse signal input will cause the totalizer value to count in the opposite direction and eventually no longer be in an overflow condition.

PROGRAM DECIMAL POINT POSITION FOR THE TOTALIZER

The decimal point position for the totalizer are as follows:

"dECPN" < > "0"
 "0.0"
 "0.00"
 "0.000"
 "0.0000"

PROGRAM TOTALIZER/INTEGRATOR TIME BASE

The time base determines the rate at which readings increase. The totalizer display is updated 2 1/2 times per second regardless of time base selected, but longer time bases decrease the magnitude of each increase. The three time bases are per second, per minute and per hour. A constant signal input of 1000 units, for example, would totalize to 1000 units in one second (*with a TB of 1 sec.*), 1000 units in one minute (*with a TB of 1 min.*), and 1000 units in one hour (*with a TB of 1 hr.*). (*Note: Input changes can be made synchronous to the display by programming E1 or optional E2-CON pin for function 13, Instrument reading synchronization.*) A multiplying scale factor may be used to span the standard time ranges (*or divide if scale factor < 1*). The following equation expresses the totalization process.

$$S.F. = \frac{D.T.}{I.D.} \times \frac{T.B.}{TIME} \times \frac{D.T.D.P.}{I.D.D.P.}$$

S.F. = Programmable Scale Factor
 D.T. = Desired Totalizer value for a fixed time duration
 T.B. = Programmable Time Base

TB = If Program Select Number Chosen Is: Enter in Formula
 "0" for sec. 1
 "1" for min. 60
 "2" for hr. 3600

I.D. = Input Display Value
 TIME = Actual Time period in seconds

D.T.D.P. = Desired Totalizer Decimal Point Enter in Formula
 0 1
 0.0 10
 0.00 100
 0.000 1000
 0.0000 10000

I.D.D.P. = Input Display Value Decimal Point Enter in Formula
 0 1
 0.0 10
 0.00 100
 0.000 1000
 0.0000 10000
 "tbASE" < > "0" - per second
 "1" - per minute
 "2" - per hour

PROGRAM THE TOTALIZER SCALE FACTOR

As explained in the previous programming step, a multiplying scale factor can be used to scale the update rate as required. This may be used to span the standard ranges. A scale factor of "1.000" has no effect on the standard ranges.

"SCLFAC" < > "0.001" to "100.000"

PROGRAM THE LOW-END CUTOFF (*low signal level disable*)

In order to prevent false totalization during system startup or other low process situations where totalization is undesirable, a programmable setpoint can be used to disable totalization when the scaled input signal falls below this low-end cutoff level.

"Lo-cut" < > "-99999" to "999999"

PROGRAMMING MODULE #6 - PROGRAM ALARM/SETPOINT

If the alarm option is installed, this module is used to configure the operation of the alarms to a variety of combinations. The programmable options are HI/LO acting, auto/manual reset (*latching*), tracking, assignment to signal or totalizer, display alarms, alarm values and hysteresis (*deadband*) values.

ALARM TRACKING

With alarm tracking, whenever alarm #2 is changed, alarm #1 will also change so that the offset between alarm #2 and alarm #1 remains the same. This is useful for hierarchical setpoints (*pre-alarm and alarm*) when one change applies to both alarm values. When programming from the front panel, tracking only occurs when PGM. DIS. is low (*front panel lock-out mode, alarm #1 will not appear*). Tracking will always occur if alarm #2 is modified via serial communications independent of PGM. DIS.

“trAc” <> “yES” or “NO”

DISPLAY ALARMS

If display alarms are desired, a message will flash on the display every 5-10 secs when an alarm activates. For alarm 1 the message will flash “AL1 on” and alarm 2 will flash “AL2 on”, this warns an operator of an alarm condition. The message will stop when the unit is no longer in an alarm condition.

“dISP” <> “yES” or “NO”

AUTO OR MANUAL RESET FOR ALARM #1

The reset action of alarm #1 may be programmed to reset automatically (*unlatched*) or be programmed to require a manual reset (*latched*), through either a remote input (*E1-CON or optional E2-CON*) or through the front panel. Latched alarms are usually used when an operator is required to take some action for the alarm condition.

“LAtC-1” <> “yES” or “NO”

ALARM #1 ASSIGNMENT TO INPUT SIGNAL OR TOTALIZER

Alarm #1 may be programmed to activate on either the input signal or the totalizer value. If the totalizer option is not installed, this step defaults to the input.

“ASN-1” <> “INPUt” or “totAL”

PROGRAM VALUE FOR ALARM #1

The range of the alarm value is -99,999 to 999,999.

“AL-1” <> “-99999” to “999999”

PROGRAM HYSTERESIS VALUE FOR ALARM #1 (Cannot be programmed if alarm latch is programmed)

The hysteresis (*deadband*) value for alarm #1 may be programmed from 1 to 99,999. The value is either added to or subtracted from the alarm value depending on whether the alarm is high or low acting. (*See “alarms” section for operation.*)

“HyS-1” <> “1” to “999999”

ALARM #1 HIGH OR LOW ACTING

The action of alarm #1 may be programmed to activate either when the signal goes above the alarm value (*high acting*) or goes below it (*low acting*).

“Act-1” <> “HI” or “LO”

AUTO OR MANUAL RESET FOR ALARM #2

The reset action of alarm #2 may be programmed to reset automatically (*unlatched*) or be programmed to require a manual reset (*latched*), through either a remote input (*E1-CON or optional E2-CON*) or through the front panel. Latched alarms are usually used when an operator is required to take some action for the alarm condition.

“LAtC-2” <> “yES” or “NO”

ALARM #2 ASSIGNMENT TO INPUT SIGNAL OR TOTALIZER

Alarm #2 may be programmed to activate on either the input signal or the totalizer value. If the totalizer option is not installed, this step defaults to the input.

“ASN-2” <> “INPUt” or “totAL”

PROGRAM VALUE FOR ALARM #2

The range of the alarm value is -99,999 to 999,999.

“AL-2” <> “-99999” to “999999”

PROGRAM HYSTERESIS VALUE FOR ALARM #2 (Cannot be programmed if alarm latch is programmed)

The hysteresis (*deadband*) value for alarm #2 may be programmed from 1 to 999,999. The value is either added to or subtracted from the alarm value depending on whether the alarm is high or low acting. (See “alarms” section for operation.)

“HyS-2” <> “1” to “999999”

ALARM #2 HIGH OR LOW ACTING

The action of alarm #2 may be programmed to activate either when the signal goes above the alarm value (*high acting*) or goes below it (*low acting*).

“Act-2” <> “HI” or “LO”

Note: Depending on options selected under Pro 3 and Pro 6, alarms, hysteresis, peak, and valley values can be monitored and/or changed when PGM. DIS. is tied to COMM. This provides a “QUICK PROGRAMMING” method for “day to day” process changes. (See QUICK PROGRAMMING SECTION for more details.)

PROGRAMMING MODULE #7 - PROGRAM SERIAL COMMUNICATIONS

Several programmable parameters must be programmed before serial communication can occur.

BAUD RATE

Select one of the baud rates from the list to match the baud rate of the printer, computer, controller, etc.

"bAud" < >	"300" - 300 baud
	"600" - 600 baud
	"1200" - 1200 baud
	"2400" - 2400 baud

UNIT ADDRESS NUMBER

To allow multiple units to communicate on the 20 mA loop, different address numbers must be assigned to each unit. If only one unit is on the loop, an address of "0" may be given, eliminating the need for the address command.

"AddrES" < > "0" to "99"

PRINT REQUEST FUNCTION

A selection of print operations can be programmed. A print operation occurs when a print request is activated via E1-CON (TBA #4,) or optional E2-CON (TBA #8) pin, or a "P" command is sent from a terminal via the serial communications option. If the option to which a particular print code applies is not installed, then that parameter will not be printed.

If the totalizer is overflowed, an asterisk (*) will precede the digits that are printed (ex. *000127 positive overflow, -*00127 negative overflow). If the input is overloaded the print-out will be "OLOLOL" and for underload "ULULUL".

"Print" < >	"0" - input signal
	"1" - input signal, peak, valley and tare
	"2" - input signal, alarm 1, and alarm 2
	"3" - input signal, alarm 1, alarm 2, hysteresis 1, hysteresis 2, peak, valley, and tare
	"4" - totalizer
	"5" - input signal and totalizer
	"6" - input signal, totalizer, peak, valley, and tare

"7" - totalizer, alarm 1, and alarm 2
"8" - input signal, totalizer, alarm 1, and alarm 2
"9" - input signal, totalizer, alarm 1, alarm 2, hysteresis 1, hysteresis 2, peak, valley, and tare

FULL OR ABBREVIATED TRANSMISSION

When transmitting data, the IMP can be programmed to suppress the address number, mnemonics and some spaces, if desired by selecting "NO". A selection of "NO" results in faster transmission. This feature may be helpful when interfacing with a computer. When interfacing to a printer, a "yES" response is usually desirable.

"FULL" < > "yES" or "NO"

An example of full and abbreviated transmission is shown below:

2 INP -125.75 < CR > < LF >	Full transmission
-125.75 < CR > < LF >	Abbreviated transmission

PROGRAMMING MODULE #8 - PROGRAM RE-TRANSMITTED ANALOG OUTPUT

This programming module allows digital scaling of the 4 to 20 mA or 0 to 10 VDC analog output. The type of analog output is determined by the model ordered. (See Ordering Information for available models.) The display value at which 4 mA or 0 VDC and the display value at which 20 mA or 10 VDC are transmitted are keyed-in. The indicator automatically calculates slope and intercept values to complete the scaling. The output may also be programmed to proportionally re-transmit the contents of the totalizer instead of the input. Reverse acting output can be achieved by programming the “high” display value for the “AN-LO” programming step and the “low” display value for the “AN-HI” step.

Note: DO NOT ADJUST THE ANALOG OUTPUT POTS ON THE BACK OF THE UNIT. Fine offset and span adjustment pots are externally accessible to compensate for small drifts in the output. These pots have been set at the factory and do not normally require adjustment.

ANALOG OUTPUT SOURCE

Program whether the input signal or the totalizer will serve as the basis for the analog output signal. If the totalizer/linearizer option is not installed, then this step defaults to “Input”.

“ASIN” <> “InPut” or “totAL”

ANALOG OUTPUT LO DISPLAY VALUE

Program the display value at which the analog output transmits 4 mA or 0 VDC.

“AN-LO” <> “-99999” to “999999”

ANALOG OUTPUT HI DISPLAY VALUE

Program the display value at which the analog output transmits 20 mA or 10 VDC.

“AN-HI” <> “-99999” to “999999”

PROGRAMMING MODULE #9 - SERVICE OPERATIONS

The indicator has been fully calibrated at the factory and will only require a scaling operation (*Pro 1 or 2*) to display the units of the process. If the unit appears to be indicating incorrectly or inaccurately, refer to the troubleshooting section before attempting this procedure.

When re-calibration is required (*generally every 2 years*), this procedure should only be performed by qualified technicians using appropriate equipment. Signal source accuracies of 0.01% or better are required.

The procedure consists of applying accurate signal levels to the indicator in a series of three steps. Allow a 30 minute warm-up period before starting this procedure.

Note: Once the access Code 48 has been entered, there is no exiting this program module without completing the calibrating procedure.

ENTER ACCESS CODE

A code number (*48*) must be keyed-in prior to the calibration sequence to guard against inadvertent entries. Access code numbers other than those listed in this section, should not be entered at this step. If any are entered, undefined or unpredictable operation could result.

“CodE” <> “0” to “99”

If the code number for the previous step was not recognized, the indicator returns to “*Pro 0*”, with no action taken. Otherwise, the calibration procedure is started.

ENTER ZERO REFERENCE

Apply 0 mA by opening the signal input wires.

“StEP 1” (Press “P”)

ENTER 50% OF PROCESS

Apply 25 mA. Allow the signal to stabilize for 20 seconds before pressing “P”.

“StEP 2” (Press “P”)

The indicator will display “*StEP -*” for ten seconds. During this interval, keep the signal level applied until “*StEP 3*” appears.

ENTER 100% OF PROCESS

Apply 50 mA. Allow the signal to stabilize for 20 seconds before pressing “P”.

“StEP 3” (Press “P”)

Indicator calibration is complete. It is recommended that calibration be checked by entering “*Pro 1*” and checking the displayed input values with the signal source at different applied input levels.

SERIAL HARDWARE (loop-back) DIAGNOSTICS

The internal serial communications hardware in the IMP can be tested to verify proper operation. The procedure consists of connecting the Serial Input (SI), Serial Output (SO), and 20 mA Source into a simple loop, and then entering an access code.

Connect the IMP as shown below. Enter “*Pro 9*”, key-in “*Code 39*”, and then press “P”. If the serial communication hardware is OK, “PASS” will be displayed. Conversely, if there is an internal problem, “FAIL” will be displayed. After the diagnostic test is complete, press “P” to return to “*Pro 0*”.

“CodE” <> “39”

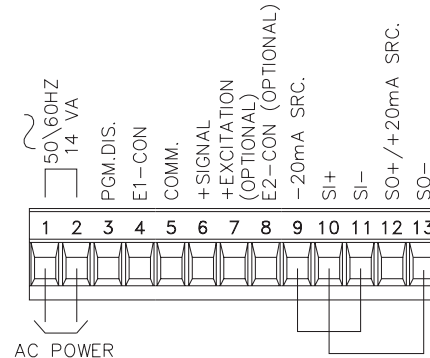

TBA

RESTORING ALL PROGRAMMING PARAMETERS BACK TO FACTORY CONFIGURATION

All of the programming in Modules #1 through #8 can be restored back to the factory configuration by entering a specific access code (refer to the "Factory Configuration" section for the data that will be entered). The procedure consists of entering "Pro 9", keying-in "Code 66", and then pressing "P". The IMP responds by displaying "INITIAL" for several seconds, and then returns to "Pro 0".

Note: When this procedure is performed, all of the scaling, presets, etc. that were programmed into the IMP will be overwritten.

"CODE" <> "66"

OPERATING THE IMP

After completing scaling and all set-up operations, the unit is ready to install and operate. After power is applied, a display test consisting of illuminating all segments for 2 seconds is performed. Afterward, the input or total will appear, depending upon the display mode prior to the last power-down. To switch the display to input, press "DOWN" (indicated by "arrows" on the front panel) and to switch it to total, press "UP". If the totalizer/linearizer option is not installed, then display switching to total is inoperative. A minus sign "-" will precede numbers that are negative. If a decimal point is chosen, one leading and one or more trailing zeros will accompany the decimal point.

QUICK PROGRAMMING

To limit access to the set-up parameters, connect a key-switch or wire from PGM. DIS. (TBA #3) to COMM. (TBA #5). With this pin connected to common, only a predetermined amount of data can be viewed or altered, as programmed by programming module #3. If "NO" was programmed for all of the available steps in module #3, then pressing "P" will cause the unit to display "Loc". However, if "YES" was programmed in one or more of the steps, then "P" will invoke entry into a series of commonly modified parameters while protecting the crucial set-up information. This is referred to as the "quick programming" mode. When "quick programming" mode is entered, the alarms and hysteresis values can be modified in the same manner as in the regular programming mode. The new alarm and hysteresis values will take effect when "P" is pressed. The other operations in the quick programming" mode require special key sequences as shown at right.

To reset latched alarm, scroll through steps in "quick programming" mode using the "P" button until "LATCHI" or "LATCH2" appears in the display. If they do not appear, they are not latched.

To reset: While "LATCHI" or "LATCH2" is being displayed, press and hold "DOWN" and press "P". Pressing "P" alone causes a step to the next item with no action taken on the alarm.

To reset peak and valley buffers, scroll through steps in "quick programming" mode using the "P" button until "PEA" or "VAL" appears in the display.

To reset: While "PEA" or "VAL" is being displayed, press and hold "DOWN" and press "P". Pressing "P" alone causes a step to the next item with no action taken on the buffer.

The front panel buttons are not only used to input data during the programming and "quick programming" mode, but control a number of other functions (if enabled in Pro "3") as well. In the normal meter mode, these functions are available:

To Switch to display of input: Press "DOWN" button.

To Switch to display of totalizer: Press "UP" button.

To re-zero input (tare): Press and hold "DOWN" and press "P".

To reset totalizer to zero: Press and hold "UP" and press "P".

To Enter programming or "quick programming": Press "P".

After each operation, a message will appear briefly to acknowledge the action.

FACTORY CONFIGURATION

The following chart lists the programming of the unit when shipped from the factory. (Code 66 will restore the unit to these values.)

"Pro 2".....	"dECPNt"	-	0.00	"Pro 6".....	"trAc"	-	NO
	"round"	-	0.01		"dISP"	-	NO
	"dSP 1"	-	0.00		"LAtC-1"	-	NO
	"INP 1"	-	4.000		"ASN-1"	-	INPUt
	"dSP 2"	-	100.00		"AL-1"	-	0.00
	"INP 2"	-	20.000		"HYS-1"	-	0.01
	"SEgt"	-	1	"Act-1"	-	HI	
"Pro 3".....	"dSP AL"	-	yES	"LAtC-2"	-	NO	
	"Ent AL"	-	yES	"ASN -2"	-	INPUt	
	"dSPHYS"	-	yES	"AL-2"	-	0.00	
	"EntHYS"	-	yES	"HYS-2"	-	0.01	
	"rStAL"	-	yES	"Act-2"	-	HI	
	"dSPbUF"	-	yES	"Pro 7".....	"bAud"	-	1200
	"rStbUF"	-	yES		"AddrES"	-	0
	"SEldSP"	-	yES		"Print"	-	0
	"rSttOt"	-	yES	"FULL"	-	yES	
"tArE"	-	yES	"Pro 8".....	"ASIN"	-	input	
"Pro 4".....	"FILtEr"	-		1	"AN-Lo"	-	0.00
	"E1-CON"	-		4 (display hold)	"AN-HI"	-	100.00
	"E2-CON"	-	4 (display hold)				
"Pro 5".....	"dECPNt"	-	0				
	"tbASE"	-	0				
	"SCLFAC"	-	1.000				
	"Lo-cut"	-	0.00				

PROGRAMMING EXAMPLE

As an example of a programming sequence, the following values, gained from a flow application, are programmed into the indicator.

DISPLAY: 100.0 gallons/minute at 4.000 mA

3000.0 gallons/minute at 20.000 mA Resolution of 0.1 gallons. Minimal filtering. Activate alarm #1 output when flow falls below 100 Gallons/min, activate display alarm. Peak and valley (max/min) readings for each day to be recorded.

TOTALIZER: When total exceeds 8000.0 then latch alarm #2 which stops flow. Alarm must be manually reset. Reset alarm #2 by remote input. Disable totalization when flow falls below 100.0

SERIAL: Provide hardcopy print-out of total, input and peak/valley when operator actuates print request. Baud rate 300.

ANALOG RE-TRANSMISSION: Reverse acting output for control value 4mA at 2000.0 g/min and 20 mA at 0.0 g/min.

"Pro 1"....."dECPNt"	-	Enter 0.0
"round"	-	Enter 0.1
"SCALE"	-	Enter yes
"dSP 1"	-	Enter 100.0
"INP 1"	-	Apply 4.000 mA
"dSP 2"	-	Enter 3000.0
"INP 2"	-	Apply 20.000 mA
"SEGT"	-	Enter 1

"Pro 2".....Not required since scaling done in "Pro 1".

"Pro 3"....."dECPNt"	-	Enter yes
"ENT AL"	-	Enter yes
"dSPHYS"	-	Enter no
"rSt AL"	-	Enter no
"dSPbUF"	-	Enter yes
"rStbUF"	-	Enter yes
"SEldSP"	-	Enter yes

"rSttOt"	-	Enter yes
"tArE"	-	Enter no

"Pro 4"....."dECPNt"	-	Enter 0
"E1-CON"	-	Enter 8 (reset alarm #2)
"E2-CON"	-	Enter 14 (print request)

"Pro 5"....."dECPNt"	-	Enter 0.0
"tbASE"	-	Enter 1
"SCLFAC"	-	Enter 1.000
"Lo-cut"	-	Enter 100.0

"Pro 6"....."trAc"	-	Enter no
"dISP"	-	Enter yes
"LAtC-1"	-	Enter no
"ASN-1"	-	Enter input
"AL-1"	-	Enter 100.0
"HYS-1"	-	Enter 1.0
"Act-1"	-	Enter LO
"LAtC-2"	-	Enter yes
"ASN -2"	-	Enter total
"AL-2"	-	Enter 8000.0
"HYS-2"	-	N/A
"Act-2"	-	Enter HI

"Pro 7"....."bAud"	-	Enter 300
"AddrES"	-	Enter 0
"Print"	-	Enter 6
"FULL"	-	Enter yes

"Pro 8"....."ASIN"	-	Enter input
"AN-Lo"	-	Enter 2000.0
"AN-HI"	-	Enter 0.0

PRESSURE MONITORING EXAMPLE

An IMP indicator is installed as a monitoring device for pressure levels within an industrial boiler. A pressure transducer with a range of 0-1500 PSI and a corresponding 4 to 20 mA output is selected. The maximum allowable pressure of the boiler is 1200 PSI, at which time a pressure relief valve will operate (*this makes the system inherently safe*). In addition, when the relief valve trips, fuel delivery to the boiler must be stopped. The relay option of the indicator is employed to turn off the fuel at 1200 PSI. To provide for fail safe operation, operator intervention is required to reset the latched relay in order to re-start the boiler. The indicator's other output is used to signal operators with a warning bell when high pressures exist (*1100 psi*), so that they may take action to prevent boiler shut-down. The alarm/setpoint values are set up for tracking, so changing the cut-off alarm value changes the other alarm value an equal amount. The indicator is programmed to provide a display of active alarms in both cases. Key switches are installed in the panel to lock-out the front panel from operators and to provide the means to reset the latched relay to re-start the boiler. The linearizer/totalizer option is specified to integrate the average boiler pressure over discrete time periods (*ie. overnight, during peak use, start-up, etc*). Peak pressures are automatically stored with this option. Programming module #5 (*Pro 5*) is used to set up the integrator. The re-transmitted analog output is also specified to drive a chart recorder with 4 to 20 mA for a hard copy of pressure profiles for later evaluation.

Scaling of the indicator is done by programming module #1 (*Pro 1*). For dSP 1, 0 PSI is keyed-in. For INP 1, the transmitter is powered and connected to the indicator and the boiler is at 0 PSI. The indicator then measures the output from the transmitter. For dSP 2, 1000 PSI is keyed-in. Prior to INP 2, the boiler is fired and brought to 1000 PSI as checked by a reference pressure gage. Once stabilized, the indicator is allowed to measure the output of the transducer for INP 2. Since there are no span/zero interactions, scaling is complete.

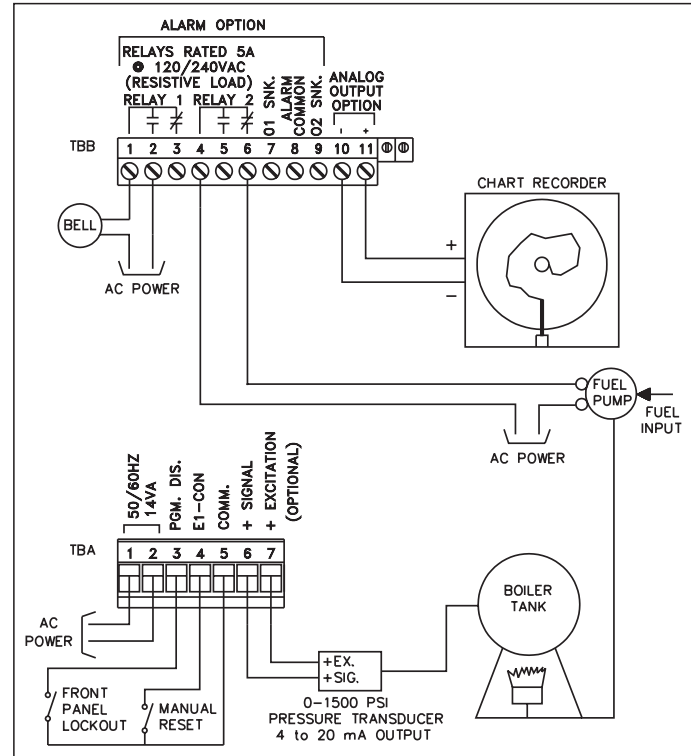

EXCITATION (Optional)

The optional regulated excitation voltage (18 VDC, 60 mA max.) can be used to power the transducer. The common of the excitation voltage is internally connected to "COMM" (TBA #5). The excitation voltage is **NOT** to be used for powering relay coils, serial communication loops, etc., due to the sensitive nature of signal common.

TOTALIZER/LINEARIZER/PEAK/VALLEY/TARE

(OPTIONAL)

TOTALIZER

The totalizer option simply totals (*adds*) input readings together using a programmable time base and scaling coefficient. The decimal point position of the totalizer can be programmed independent of the input signal. The totalizer may be reset through a remote input, by the front panel or through the serial communications option. Alarms may be programmed to trigger from totalizer values; for example to total flow for batching operations. The programmable time bases are "per second", "per minute" and "per hour", meaning the totalizer will accumulate at a fixed rate of 2½ times per second and be equal to a fixed input signal level over the selected time period. For example, if the input signal is a constant 1000 units and the "per minute" time base is selected, the totalizer will accumulate at the rate of 1000 units per minute. The totalizer is updated at this rate every 400 msec. As a result, the input signal is accumulated in "batches" of 6.6 counts every 400 msec. Therefore, the totalizer start and stop sequencing, as well as, the alarm values set to trigger at specific totalizer values, are accurate only to the 400 msec totalizer update rate. The preceding example requires a scale factor of 1.000 to yield exact time bases, but any scale factor can be used to span between the ranges. (See section on totalizer programming for detailed information.) A programmable low signal level disable feature completes the totalizer features (*this will stop totalization when the signal level drops below this programmed value, "low cut"*). At loss of power to the indicator, the contents of the totalizer are saved. This will allow totalizing over consecutive shifts, days, etc. The total can accumulate to 999,999. If the low-end cutout value is programmed negative (*ex. -100, reference Program Module #5*), and the input signal is between zero and the low-end cutout value, the totalizer value will decrement. If the input signal goes above zero the total will increment. If the signal goes below (*more negative than*), the low-end cutout value, totalization will stop.

Note: The totalizer value will roll over and flash when the total exceeds, 999999 or -99999, indicating an overflow condition. Reverse signal input will cause the totalizer value to count in the opposite direction and eventually no longer be in an overflow condition.

TOTALIZER EXAMPLE

The indicator is employed to indicate and totalize the electrical power consumption of a factory. A power meter with a 4-20 mA output that corresponds to 0 to 10 kW is selected. The input is scaled to read instantaneous power draw in kilowatts with 0.001 kW resolution and the totalizer is scaled to read kilowatt-hours. The following programming steps are followed:

BASIC SCALING

"Pro 2"....."dECPNT"	-	0.000
"round "	-	0.001
"dSP 1"	-	0.000
"INP 1"	-	4.000
"dSP 2"	-	10.000
"INP 2"	-	20.000

TOTALIZER SET-UP

With an average signal input which gives a Process Display of 1.000 kW for a one-hour time period, the following formula applies:

$$S.F. = \frac{D.T.}{I.D.} \times \frac{T.B.}{TIME} \times \frac{D.T.D.P.}{I.D.D.P.}$$

S.F. = Programmable Scale Factor

D.T. = Desired Totalizer value for a fixed time duration

T.B. = Programmable Time Base

TB = If Program Select Number Chosen Is: Enter in Formula

"0" for sec.	1
"1" for min.	60
"2" for hr.	3600

I.D. = Input Display Value

TIME = Actual Time period in seconds

TOTALIZER SET-UP (Cont'd)

D.T.D.P. = Desired Totalizer Decimal Point

0
0.0
0.00
0.000
0.0000

Enter in Formula

1
10
100
1000
10000

I.D.D.P. = Input Display Decimal Point

0
0.0
0.00
0.000
0.0000

Enter in Formula

1
10
100
1000
10000

$$S.F = \frac{1KW}{1.000KW} \times \left(\frac{3600^{**}}{3600} \right)^* \times \frac{1}{1000}$$

$$S.F = \frac{1}{1000}$$

$$S.F. = .001$$

"Pro 5".....	"dECPNT"	-	0
	"tbASE"	-	2
	"SCLFAC"	-	0.001
	"Lo-cut"	-	0.000

The totalizer will totalize up to 999,999 Kilowatt hours.

Alternatively, the totalizer can be scaled to indicate in terms of dollars and cents of consumed power. If the rate of electricity is 7 cents/kWH then the following set-ups are made:

$$S.F = \frac{.07 / KW}{1.000KW} \times \left(\frac{3600^{**}}{3600} \right)^* \times \frac{100}{1000} \quad SF = .007$$

"Pro 5".....	"dECPNT"	-	0.00
	"tbASE"	-	2
	"SCLFAC"	-	0.007
	"Lo-cut"	-	0.000

The totalizer will totalize up to 9999.99 dollars in .01 dollar resolution.

*This value is normally 1, but can be used as a coarse scale factor of 60 or 3600.
**Since the time period is in Hrs., the selected T.B. is 3600 (Program Select Value = 2) which equals per hour (3600 sec.)

LINEARIZER

The linearizer feature is a series of programmable scaling points that are used to construct linear segments to linearize the input signal. The most common application would be to interface with square law devices (*commonly, flow transducers*). Correction for non-linearity is accomplished by continuing with scaling points beyond "DSP 2" and "INP 2" in "Pro 1" or "Pro 2", with "DSP 3", and "INP 3", "DSP 4", and "INP 4", etc. The unit automatically calculates the linear segments between the programmed coordinates. This process of entering linear segments is also known as "curve fitting". A maximum of nine segments are available and using nine segments for a square law device would reduce linearity errors to approximately .35%. No restriction is placed on the ordering of the scaling points as long as the input signal scaling points are all increasing or all decreasing. To have one or more points "back-track", the input/output (signal/display) relationship would not be a function and would be undefined in that area. Additionally, consideration should be given to the location and length of each segment to fully minimize the segment conformity error over the desired range. A typical curve is shown below using five segments (six scaling points). Usually it is desirable to use as many segments as possible to reduce the amount of linearity error.

LINEARIZING FUNCTION

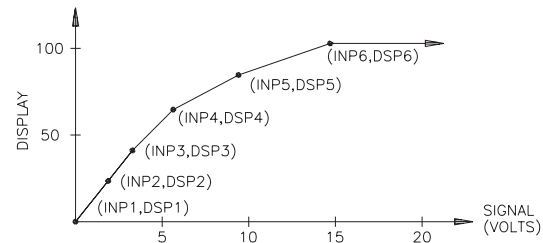

LINEARIZER (Cont'd)

The computer program in Appendix "C" outputs the display and process (input) scaling points (*the location of each linear segment*) as a percentage of the full scale input (*eg. 4-20 mA*) and full scale display (*eg. 0-1000 gpm*). To obtain the actual input and display scaling points, multiply the respective percent of full scale values by the respective full scale range for the input and the display. "Pro 2" is then used to enter these values into the IM unit. Certain linear sections of a given curve may have a slope which exceeds the measuring resolution of the instrument. The effect will be an erratic display in that part of the curve, if not corrected (*generally, if slope 2counts/uA*). Correcting for this condition consists of three steps: increase digital filtering to level 1 or level 2, decrease display resolution to 2 or 5 or add dummy right hand zeros by programming 10 or 100 for "round".

The following display and process percentage tables were derived from the computer program in Appendix "C" (*Reference Appendix C section for more details*). The display and process percentage tables listed below can be used for ANY square law (*square root extraction*) device.

The results of the computer program are as follows:

Number of linear segments = 9

Curve fitting error (%) = .35

Display Values (% of Range)	Process Values (% of Range)
0.00	0.00
6.32	0.20
10.43	1.00
18.04	3.10
27.58	7.40
39.09	15.00
52.61	27.30
68.18	46.00
85.74	72.90
100.00	100.00

As an example, to linearize a 4-20 mA flow transmitter, with the following flow equation:

$$\text{Flow(gpm)} = 44.7\sqrt{\Delta P}$$

where: P = 0-500 PSI

Flow = 0-1000 gpm

Now, using the above percentages, the actual process (*input*) signal and display scaling points must be calculated. To do this for the display values, it is simply the display percentage times the full scale display range. i.e. 18.04% x 1000 gpm = 180.04; 68.18% x 1000 = 681.8 etc.

To calculate the process (*input*) values, multiply the process percentage times the full scale process differential, then add in the process offset value. i.e. For the process range of 4-20 mA, [3.10% x (20 mA - 4 mA)] + 4 mA = 4.496 mA; [27.30% x (20 mA - 4 mA)] + 4 mA = 8.368 mA. If the process range were 10-50 mA, then the results would be as follows: [3.10% x (50 mA - 10 mA)] + 10 mA = 11.24 mA; [27.30% x (50 mA - 10 mA)] + 10 mA = 20.92 mA.

The tables below show the scaling points calculated for the 4-20 mA process (*input*) along with the corresponding display values.

DISPLAY		PROCESS (INPUT)	
(%FS,	0-1000 gpm*)	(%FS	4-20 mA*)
0.00	0	0.00	4
6.32	63.2	0.20	4.032
10.43	104.30	1.00	4.16
18.04	180.40	3.10	4.496
27.58	275.80	7.40	5.184
39.09	390.90	15.00	6.400
52.61	526.10	27.30	8.368
68.18	681.80	46.00	11.360
85.74	857.40	72.90	15.664
100.00	1000.00	100.00	20.000

* The values shown in this column are user calculated.

Note: These full scale percentage values for process and display can be applied to ANY square law device.

The example below shows a 10-50 mA square law transducer using the same percent of full scale numbers with nine segments as the 4-20 mA device.

$$\text{Flow(gpm)} = 42.4\sqrt{\Delta P}$$

where: P = 0-1250 PSI

Flow = 0-1500 gpm

DISPLAY		PROCESS (INPUT)	
%FS,	10-50 mA*	%FS,	0-1500 gpm*
0.00	0	0.00	10
6.32	94.8	0.20	10.08
10.43	156.45	1.00	10.40
18.04	270.60	3.10	11.24
27.58	413.70	7.40	12.96
39.09	586.35	15.00	16.00
52.61	789.15	27.30	20.92
68.18	1022.70	46.00	28.40
85.74	1286.10	72.90	39.16
100.00	1500.00	100.00	50.00

Examination of the data of the first example reveals a slope in the first linear segment of $63.2 / (4.032 - 4.000) = 20$ display units/uA, which exceeds the value at which display stability is sacrificed (2 units/uA). Increasing the digital filtering to level 1 stabilizes the display at low flow rates to acceptable levels, at the expense of increased response time. Rounding the display to 0.2, 0.5 or 1.0 gpm further increases stability at a sacrifice of display resolution. The linear slopes at higher flow rates are well within the indicator's capability and are very stable. Following with the example of 0.1 gpm resolution, the values to be entered in "Pro 2" to program this example are:

"dECPNT"	"0.0"	- Defines decimal point
"round"	"0.1"	- Defines rounding factor and dummy zeros
"SCALE"	"yes"	- Continue with scaling program
"dSP 1"	"0.0"	- Program first display point
"Inp 1"	"4.00"	- Program first input current point
"dSP 2"	"63.2"	
"Inp 2"	"4.032"	
"SEGt"	"9"	- Defines number of active linear segments
"SCALE"	"yes"	- Continue with scaling
"dSP 3"	"104.3"	- Program balance of scaling points
"INP 3"	"4.16"	
"dSP 4"	"180.4"	
"INP 4"	"4.496"	
"dSP 5"	"275.8"	
"INP 5"	"5.184"	
"dSP 6"	"390.9"	
"INP 6"	"6.400"	
"dSP 7"	"526.1"	
"INP 7"	"8.368"	

"dSP 8"	"681.8"
"INP 8"	"11.360"
"dSP 9"	"857.4"
"INP 9"	"15.664"
"dSP 10"	"1000.0"
"INP 10"	"20.000"

As a result of the scaling, the indicator is scaled to read directly in (*gpm*) from a non-linear pressure transducer ($4-20$ mA), with 0.5% error.

PEAK/VALLEY

The other features of the totalizer/linearizer option are peak and valley detection and a re-zero (*tare*) function. The indicator will record the lowest reading (*valley*) and the highest reading (*peak*), automatically, for later recall. This information is valuable in monitoring the limits of the process over any length of time since these values are stored at power-down to span over shifts, days, etc. An external input can be programmed to reset or engage the unit into a peak/valley reading indicator. Additionally, the peak and valley can be viewed and reset from the front panel, if so programmed, and viewed and reset from the serial communication option.

Note: The peak/valley measurement is not instantaneous and is based on a nominal 2 second response time.

TARE

The re-zero (*tare*) function can also be controlled externally, by the front panel or through serial communications. This feature can quickly compensate for small shifts or drifts in the input signal or to re-zero every operation, such as batching. If the display error is greater than 1% of span due to transducer drift, it is recommended to rescale the unit with "Pro 1" or "Pro 2", rather than re-zero the input. The tare buffer can be cleared by "stepping" through "Pro 2", using the "P" button or via serial communications.

ALARMS (Optional)

The alarm option consists of an additional printed circuit board with 9 terminals. Six of these terminals are the two Form-C relays and the other three are the two open collector transistors, which act in parallel with the relays. The two alarms are completely independent with programmable values, hysteresis (deadband), high or low acting, auto or manual reset, triggering from input or total, and tracking one another, if desired. If the alarms are programmed to latch (manual reset), then they will have to be reset either by the front panel or remote input. The alarms can be made to trigger from the totalizer instead of the input, to activate external alarms, control valves, etc. Additionally, the alarms may be programmed to activate an alarm display to alert operators of the condition.

Alarm #1 can be made to track Alarm #2 by enabling alarm tracking. This is useful in alarm set-ups where a pre-warning control activates before a second alarm shuts off the process. When tracking is programmed, changing the shut-off trip value (*Alarm #2*) automatically changes Alarm #1 so that the offset between Alarm #2 and Alarm #1 remains the same. Alarm and hysteresis values can be

modified through the optional serial communications to provide automatic control. The following diagrams depict how the alarms work with both “HI” and “LO” acting set-ups.

Programming of the alarms can be done in the normal programming mode “Pro 6” or the unit can be programmed so that the values can only be changed in the “quick programming” mode.

If the display should indicate an “OLOLOL” or “ULULUL” the alarms will deenergize, whether they are latched or unlatched.

Note: Alarm Comm. (TBB #8) must be kept isolated from Analog “-”.

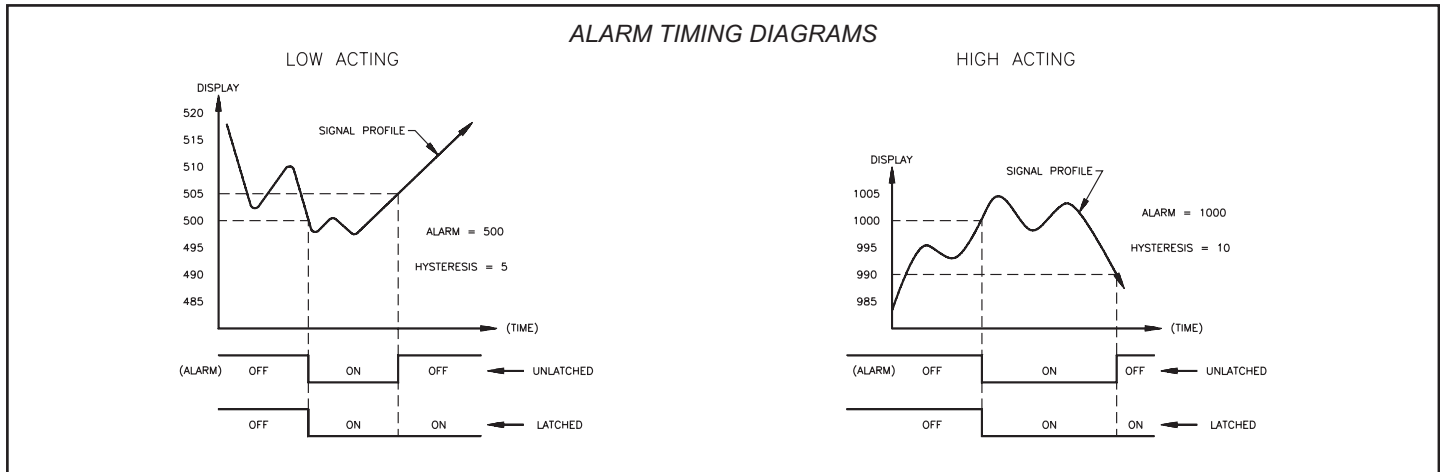

20 mA CURRENT LOOP SERIAL COMMUNICATIONS (Optional)

GENERAL DESCRIPTION

The serial communication option is a half-duplex, two-way, 20 mA loop that can connect to a variety of printers, computers, terminals and controllers to suit many data-polling or automatic operation applications. The indicator responds to a host of commands, including change alarm value, reset totalizer and transmit input value. Two loops are required for all hook-ups; a transmit (*out-going data*) loop and a receive (*in-coming data*) loop. Since the indicator monitors the receive loop for a busy signal (*current interrupted*) while transmitting, the receive loop must be connected even if the indicator is transmitting only, such as to a printer. A built-in 20 mA source can be used in the transmit loop (*only*) by connecting the current return wire to -20 mA SRC., instead of SO+. To bypass the built in current source, make transmit loop connections to SO+ and SO-. Additionally, multiple units and other Red Lion Controls instruments can be serially addressed, up to a maximum of 99 units. (*The actual number in a single loop is limited by the serial hardware specifications.*) To eliminate problems with ground loops, the serial circuitry is isolated from both signal common and output common. Optional 20 mA to RS232C and 20 mA to RS422 converter modules expand the unit's flexibility.

Note: When operating the unit with a printer, the receive loop of the indicator must have current flowing into it before transmission can take place.

COMMUNICATION FORMAT

Data is sent by switching current on and off in the loop and is received by monitoring the switching action and interpreting the codes that are transmitted. In order for data to be correctly interpreted, there must be identical formats and baud rates among the communicating equipment. The only format available with this indicator is 1 start bit, 7 data bits, 1 odd parity bit and 1 stop bit. The baud rates are programmable and the choices are: 300, 600, 1200 and 2400.

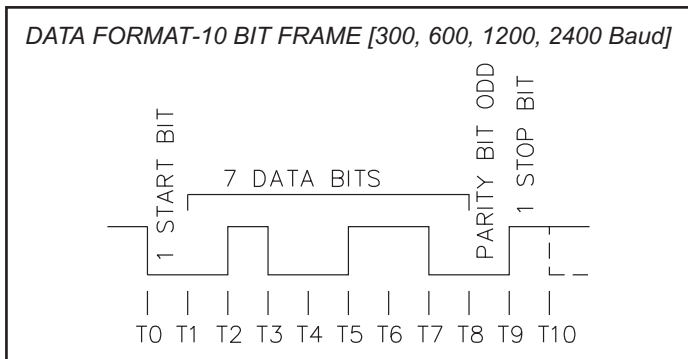

Before serial communication can take place, the indicator must be programmed to the same baud rate as the connected equipment. In addition, the loop address number, print options and full or abbreviated transmission must be programmed. If only one indicator is to be used, then a loop address number of "0" may be used, to eliminate the requirement for the address specifier when sending a command. If more than one indicator is on the loop, assignment of unique addresses, other than zero, for each indicator is recommended. Valid addresses of 0 to 99 may be assigned, but the built-in current source, if used, is capable of driving up to 7 units. Additional drive capability may be afforded by an external current source with a higher compliance voltage. Refer to programming section "Pro 7" to program the serial option.

SENDING COMMANDS TO THE IMP

When sending commands to the unit a command string must be constructed. The command string may consist of command codes, value identifiers, and numerical data. Below is a table outlining the codes the indicator will recognize.

COMMAND	FUNCTIONS
T	transmits the requested information specified by the identifier (A-I, K, and L)
V	change a value specified by the identifier (C-F, K, and L)
N	address a particular indicator in a multiple unit loop (0-99)
R	reset a value specified by the identifier (B-D, G, H, I, and J)
P	print per programmable print options (A-H)

VALUE	IDENTIFIERS	SERIAL MNEMONICS
A	input or process value	INP
B	totalizer	TOT
C	alarm #1	AL1
D	alarm #2	AL2
E	hysteresis #1	HS1
F	hysteresis #2	HS2
G	peak reading	PEK
H	valley reading	VAL
I	zero tare	TAR
J	tare input	—
K	analog low	ANL
L	analog high	ANH

Note: RJ - tares the input (rezeros). When the input is tared (via front panel or "RJ") the amount is stored in the tare reading (I). Ex. When a tare is performed, the display reads "5.0", the tare value will be "-00005.0" (and the display will show 0.0).

A command string is constructed by using the above commands and identifiers along with any data values that are required. The indicator will accept "+" or "-" in front of the data value. Numbers without "+" are understood to be positive. Leading zeros can be eliminated and both lower and upper case characters are

accepted. The address command is used to allow a command to be directed to a specific unit on the loop. If the indicator is assigned an address of "0", transmission of the address command is not required. This is done where only one indicator is in the loop.

The command string is constructed in a specific logical sequence. The indicator will reject command strings that do not conform. Only one operation can be performed per command string. Below is a description of how to construct a command string.

1. If the indicator has an address other than zero, the first two characters of the string must consist of the address command (N) followed by the unit address number (0-99). If the indicator has an address of 0, the address command is optional.
2. The next two characters in the string are the actual command the indicator must perform and the identifier on which it operates. The command P - print, has an implied operation and needs no value identifier.
3. If the change value command is being used (V), the next characters in the string after the value identifier, are the numerical data. When sending numerical data, such as change an alarm value, the correct number of digits to the right, must be included. As an example, to change an alarm value from 750.02 to 500.0. Sending 500 would cause the indicator to see 50.0 and change the alarm value accordingly.
4. All commands must be terminated by an asterisk(*). The indicator will not respond to any other code. Carriage return and line feed are not valid terminators and should be suppressed with the character ";", if using a BASIC print statement (ex. Print "N9TA*";).

COMMAND STRING EXAMPLES

Indicator with address 3, transmit input reading.

N3TA*

Indicator with address 0, change alarm #1 to 1500.

VC1500*

Indicator with address 1, reset totalizer.

N1RB*

Indicator with address 99, print the print options.

N99P*

Indicator with address 0, zero tare value.

RI*

If an illegal command or character is sent to the IM, an asterisk (*) must be transmitted to clear the input buffer. The IM will not respond to an illegal or incomplete transmission. The diagrams show the differences in the timing considerations for either Abbreviated or Full Character Transmission, or if a Reset Command is issued.

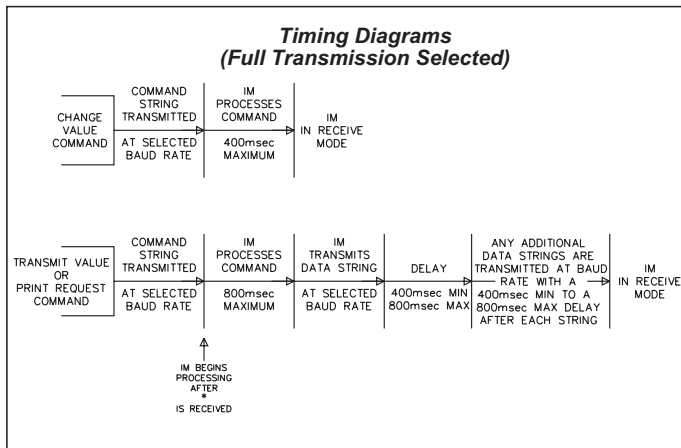
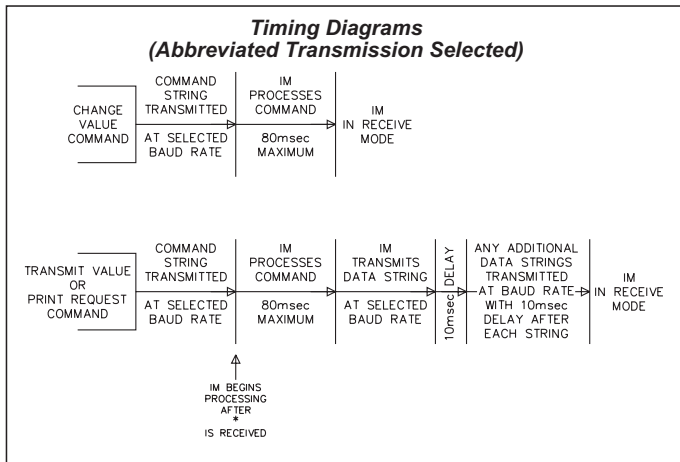

Note: If Full Transmission is selected and the front panel is being accessed at the time of transmission, the IM may take as long as 2 seconds to respond.

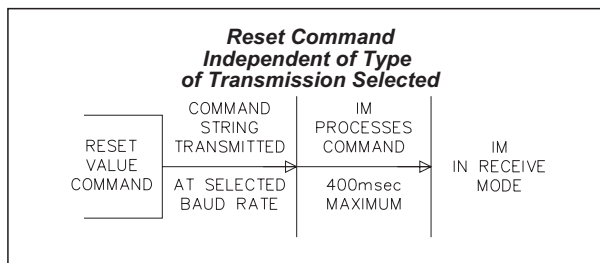

RECEIVING DATA FROM THE IMP

Data is transmitted from the indicator whenever a “T” or “P” command is received via serial communications or a remote input, E1-CON or optional E2-CON pin is programmed for print request, is activated. If the abbreviated transmission was programmed, just data will be transmitted, with no built-in delay. If full transmission is programmed, then there is a 400 msec min to 800 msec max delay built into the string. A data string transmission is shown below.

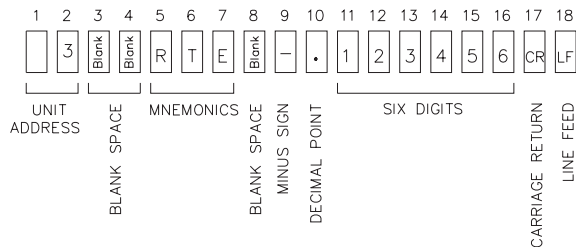

The first two characters transmitted are the unit address number, unless it is zero, in which case it is left blank, then two blank spaces are sent. The next three characters are the abbreviation for the value (*mnemonics*) which is then followed by a blank. The actual data is transmitted next. The field is right justified with leading zeros. Negative numbers are indicated by a minus sign fixed next to the identifier. A carriage return and a line feed are transmitted next. For various reasons, “extra” characters are added onto the end of the above character string. (*These characters could be and are used for control or signaling purposes.*) These characters are:

< CR> sent after single line transmissions from IM unit.

< SP>< CR>< LF> sent after “*last line of a block*” transmission from IM unit.

For a “T” command or after each “*line of a block*” transmission, no additional characters are sent. If the abbreviated transmission is selected, the address, mnemonics, and any blank spaces (*first eight characters*) are not transmitted (*the data strings are left justified in this case*).

If the transmitted data is overrunning the peripheral’s buffer, the receive channel to the indicator may be used for handshaking purposes. As a consequence of this, even if the indicator is to transmit only (*ex. to a printer*), current must be flowing in the receive channel to allow transmission.

Examples of transmissions are as follows:

2 INP -125.75 < CR> < LF> full transmission

-125.75 < CR> < LF> abbreviated transmission

This page is intentionally left blank.

CURRENT LOOP INSTALLATION

WIRING CONNECTIONS

When wiring the 20 mA current loop, remove the bottom terminal block (TBA), located on the rear of the unit. It is recommended that shielded (screened) cable be used for serial communications. This unit meets the EMC specifications using Alpha #2404 cable or equivalent. There are higher grades of shielded cable, such as, four conductor twisted pair, that offer an even higher degree of noise immunity. Refer to the numbers listed with the terminal descriptions below or those located on the label. Install each wire in its proper location on the terminal block. When all connections are made, replace the terminal block into its proper location.

SERIAL TERMINAL DESCRIPTIONS

8. **PRINT REQ.** - The Print Request terminal is pulled low to activate the unit to transmit data according to the print function selected in Program Module #7 (*Reference Programming Module #7 for more details*). In order for a print request function to occur, E1-CON (TBA #4) or E2-CON (TBA #8) pin must be programmed for print request. *Note: In order to guarantee a print-out, the programmed E-CON pin must be held low for at least 20 msec. If this time exceeds 800 msec, a second print-out may occur.*
9. **-20 mA SRC.** - 20 mA current source return path for the transmit loop. Current flows into this pin.
10. **SI+ (Serial In+)** -
11. **SI- (Serial In-)** -
The unit receives commands on the SI terminals. They are connected in series with the transmit or output terminals of the device to be connected.
12. **SO+ / +20 mA SRC. (Serial Out+)** - 20 mA current source for the transmit loop (internally connected).
13. **SO- (Serial Out-)** -
The unit transmits the requested data on the SO terminals. They are connected in series to the receive input of the device to be connected.

Note: The Serial Input terminals must be held in the mark condition (current flowing) in order for the unit to respond to a Print Request terminal activation.

SERIAL COMMUNICATIONS EXAMPLES

CONNECTING TO AN RLC PRINTER

The drawing shows the indicator with the 20 mA Serial Communication Option set-up with an RLC Model DMPC printer. An external current source is required to implement the printer's busy signal to the indicator's receive loop, which prevents overruns. The "Print switch" is a momentary contact, push button type connected between the E2-CON (TBA #8) and the signal common (TBA #5). The print function and E2-CON must be programmed, and the baud rate must match those of the printer. If a printer is used which does not have a 'busy' line, current must still be flowing into the indicator's receive loop before transmission can occur. A unit address of '0' may be assigned in this case.

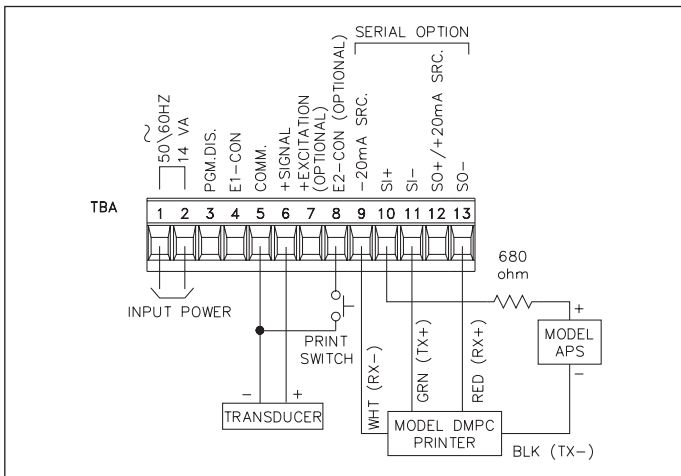

PROCESS CONTROLLING SYSTEM

Six Model IMPs with Serial Communication Option are used to monitor and control water tank levels in a plant. The IMPs are located at each of the tanks in the production area of the building. The communications lines are run to an industrial computer located in the production offices.

The drawing below shows the Current Loop set-up. Each IMP is given an address and programmed accordingly (Program Module #7). A baud rate of 1200 is selected.

An application program is written, which sends and retrieves data from the IMPs.

Note: On all IM indicators, the SO+ and the +20 mA SRC are connected internally. Therefore it is not necessary to have this terminal tied to any other terminal on the unit if that unit is serving as the loop supply source.

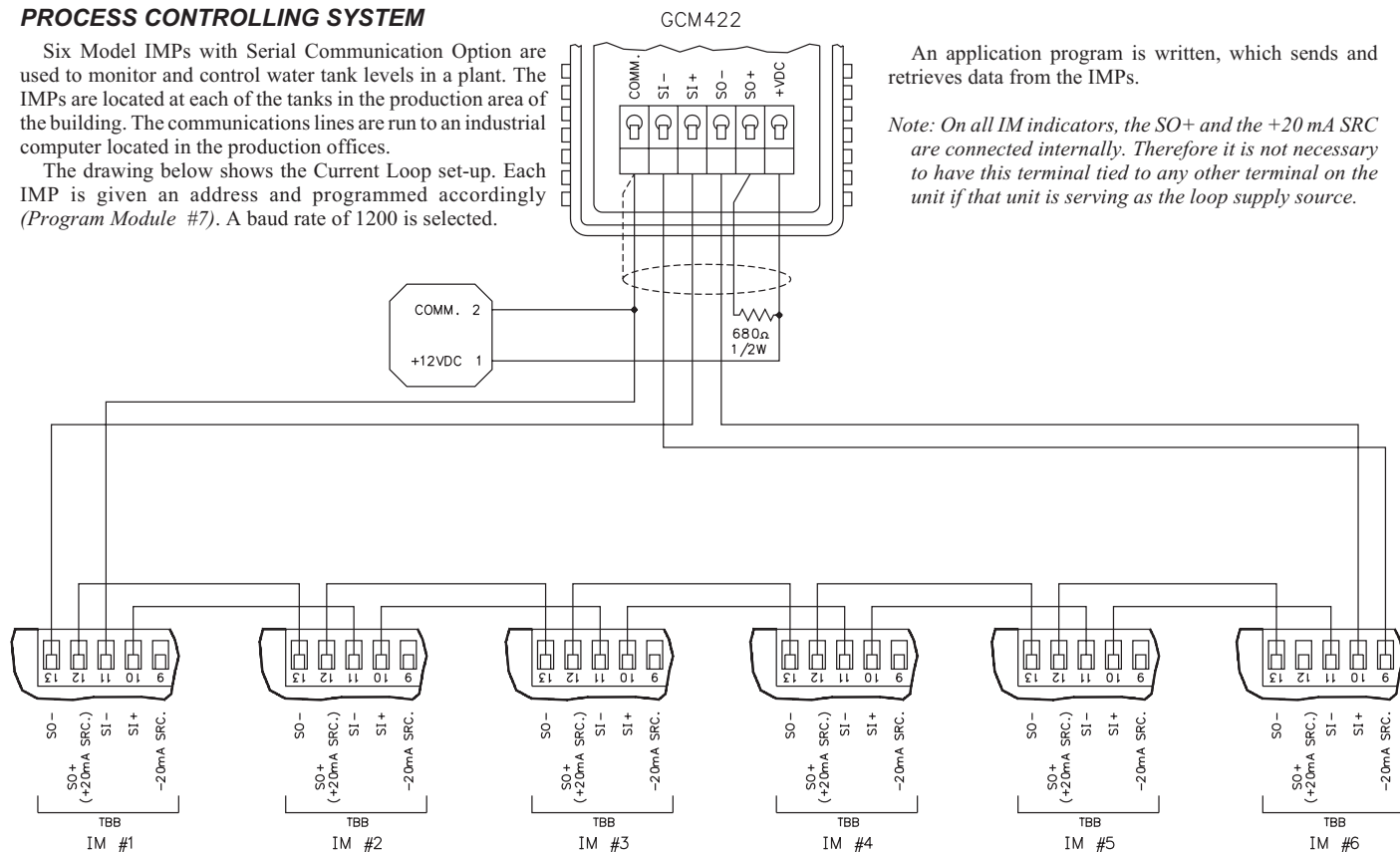

RE-TRANSMITTED ANALOG OUTPUT (OPTIONAL)

The re-transmitted analog output option transmits a digitally programmable 4 to 20 mA or 0 to 10 VDC signal to drive chart recorders, remote indicators and controllers. The option is contained on the upper PCB and has two outputs, "ANALOG-" (TBB #10) and "ANALOG+" (TBB #11) and is self-powered (active) with a compliance of 10 VDC. The analog "-" output is isolated from the signal input common, eliminating problems from ground loops. Programming of the option is performed in "Pro 8" of the normal programming mode. Display values are simply keyed in to provide a 4 mA or 0 VDC output, "AN-LO", and a 20 mA or 10 VDC output, "AN-HI".

The analog output then follows the displayed value and as such will update every measurement cycle. Nonstandard current or voltage ranges can be supported by calculating the slope and intercept of the display/output and calculating the required display values at 4 mA or 0 VDC and 20 mA or 10 VDC. Reverse action can be achieved by programming a "high" display value for "AN-LO" and a "low" display value for "AN-HI".

If the display should indicate an "OLOLOL" or "ULULUL" the analog output will go to 20 mA or 10 VDC for an open and 4 mA or 0 VDC for a short.

Note: Analog "-" must be kept isolated from alarm comm. (TBB #8).

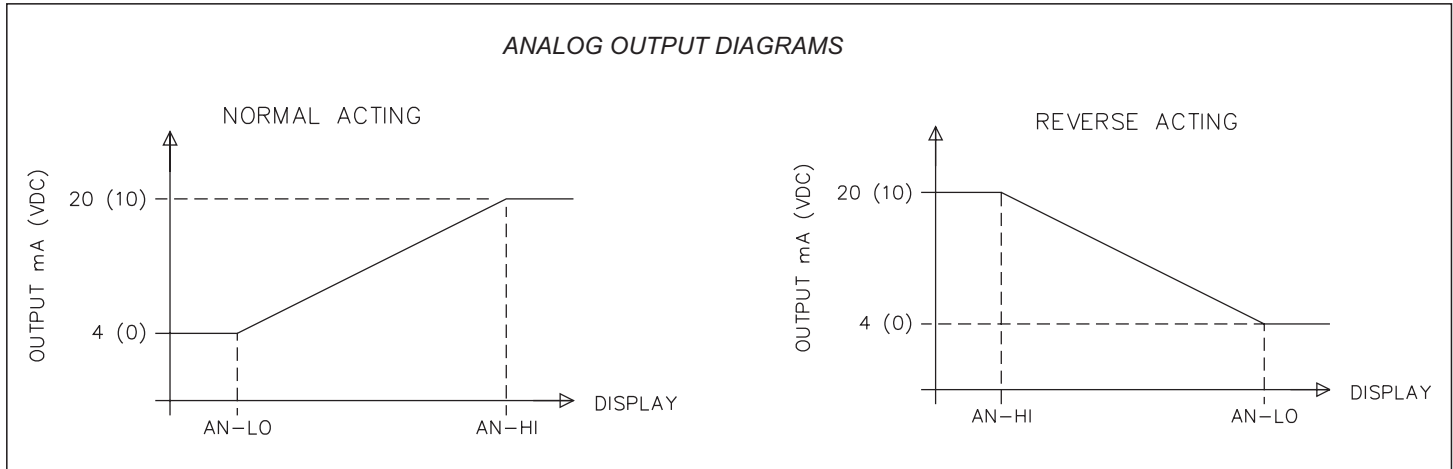

ANALOG OUTPUT CALIBRATION

Although the analog output has been calibrated at the factory, zero and span adjustments are provided to compensate for small offsets and drifts. If excessive drift is noticed, the following calibration procedure may be performed.

Scale the analog output by entering an arbitrarily larger display value for "AN-HI" then for "AN-LO" in "PRO 8".

Note: Set the analog output source assignment for input.

4 to 20 mA CALIBRATION

Exit the programming mode and apply a signal to the input of the indicator so that the display reading is below that of the value entered for "AN-LO". Adjust the zero potentiometer (*right side*) so that exactly 4.00 mA flows, as verified by an accurate ammeter. Next, apply a signal to the indicator so that the display reading is above that of the value entered for "AN-HI" (*see Appendix "B" for maximum input voltage*). Adjust the span potentiometer (*left side*) so that 20.00 mA is flowing. Repeat the zero and span adjustments until both are accurate. Analog output calibration is complete.

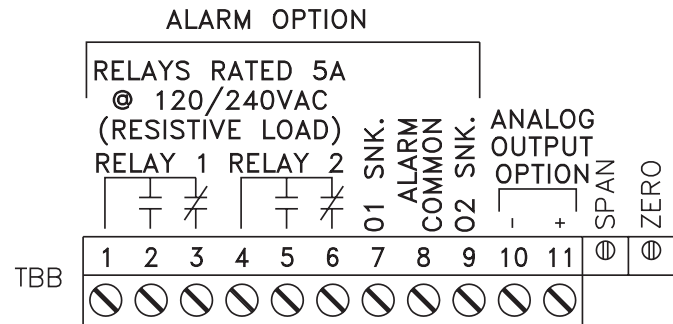

0 to 10 VDC CALIBRATION

Exit the programming mode and apply a (temperature)/(resistance) to the input of the indicator so that the display reading is below that of the value entered for "AN-LO". Adjust the zero potentiometer (*right side*) so that exactly 0.00 VDC flows, as verified by an accurate voltmeter. Next, apply a (temperature)/(resistance) to the indicator so that the display reading is above that of the value entered for "AN-HI" (*see Appendix "B" for maximum input voltage*). Adjust the span potentiometer (*left side*) so that 10.00 VDC is flowing. Repeat the zero and span adjustments until both are accurate. Analog output calibration is complete.

APPENDIX "A" - INSTALLATION & CONNECTIONS

INSTALLATION ENVIRONMENT

Before installing the IM into the panel, the user should first become familiar with the unit. It may also be desirable to program the unit for the application. When programming is complete, all parameters will be saved in non-volatile memory. The Program Disable (PGM.DIS.) terminal should be connected to COMM. to prevent accidental or unauthorized programming changes.

The unit should be installed in a location that does not exceed the maximum operating temperature and provides good air circulation. Placing the unit near devices that generate excessive heat should be avoided.

The bezel should be cleaned only with a soft cloth and neutral soap product. Do NOT use solvents. Continuous exposure to direct sunlight may accelerate the aging process of the bezel. Do not use tools of any kind (screwdrivers, pens, pencils, etc.) to operate the keypad of the unit.

PANEL INSTALLATION

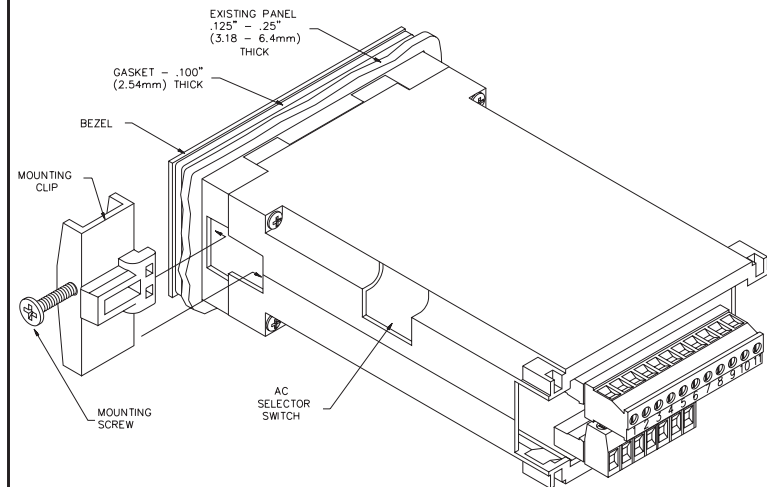

The unit meets NEMA 4/IP65 requirements for indoor use, when properly installed. The units are intended to be mounted into an enclosed panel with a gasket to provide a water-tight seal. Two mounting clips and screws are provided for easy installation. Consideration should be given to the thickness of the panel. A panel that is too thin may distort and not provide a water-tight seal. (Recommended minimum panel thickness is 1/8".)

Cut the panel opening to the specified dimensions. Remove burrs and clean around the panel opening. Slide the panel gasket over the rear of the unit to the back of the bezel.

As depicted in the drawing, install the screws into the narrow end of the mounting clips. Thread the screws into the clips until the pointed end just protrudes through the other side. Install each of the mounting clips by inserting the wide lip of the clips into the wide end of the hole, located on either side of the case. Then snap the clip onto the case. Tighten the screws evenly to apply uniform compression, thus providing a water-tight seal.

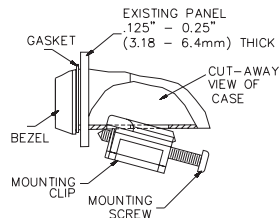

*Caution: Only minimum pressure is required to seal panel. Do **NOT** overtighten screws.*

SELECT AC POWER (115/230 VAC)

The AC power to the unit must be selected for either 115 VAC or 230 VAC. The selector switch is located through an access slot on the side of the case (See Panel Installation Figure above, or label on case). The unit is shipped from the factory with the switch in the 230 VAC position.



Caution: Make sure the AC selector switch is set to the appropriate position before applying power to the unit. Damage to the unit may occur if the AC selector switch is set incorrectly.

EMC INSTALLATION GUIDELINES

This unit complies with the ElectroMagnetic Compatibility (EMC) standard listed in the specifications. Although the unit is designed with a high degree of immunity to ElectroMagnetic Interference (EMI), proper installation and wiring methods must be followed to ensure compatibility in each application. The type of the electrical noise, source or coupling method into the unit may be different for various installations. Listed below are some EMC guidelines for successful installation in an industrial environment.

1. The unit should be mounted in a metal enclosure, which is properly connected to protective earth.
 - a. If the bezel is exposed to high Electro-Static Discharge (ESD) levels, above 4 Kv, it should be connected to protective earth. This can be done by making sure the metal bezel makes proper contact to the panel cut-out or connecting the bezel screw with a spade terminal and wire to protective earth.
2. Use of shielded (screened) cables for all Signal and Control inputs is recommended. The shield (screen) pigtail connection should be made as short as possible. The connection point for the shield depends somewhat upon the application. Listed below are the recommended methods of connecting the shield, in order of their effectiveness.
 - a. Connect the shield only at the panel where the unit is mounted to earth ground (protective earth).
 - b. Connect the shield to earth ground at both ends of the cable, usually when the noise source frequency is above 1 MHz.
 - c. Connect the shield to common of the unit and leave the other end of the shield unconnected and insulated from earth ground.
3. Never run Signal or Control cables in the same conduit or raceway with AC power lines, conductors feeding motors, solenoids, SCR controls, an heaters, etc. The cables should be run in metal conduit that is properly grounded. This is especially useful in applications where cable runs are long and portable two-way radios are used in close proximity or if the installation is near a commercial broadcaster.
4. Signal or Control cables within an enclosure should be routed as far away as possible from contactors, control relays, transformers, and other noisy components.

5. In extremely high EMI environments, the use of external EMI suppression devices, such as ferrite suppression cores, is effective. Install them on Signal and Control cables as close to the unit as possible. Loop the cable through the core several times or use multiple cores on each cable for additional protection. Install line filters on the power input cable to the unit to suppress power line interference. Install them near the power entry point of the enclosure. The following types of EMI suppression devices (or equivalent) are recommended:

Ferrite Suppression Cores for signal and control cables:

Fair-Rite # 0443167251 (RLC #FCOR0000)

TDK # ZCAT3035-1330A

Steward #28B2029-0A0

Line Filters for input power cables:

Schaffner #FN610-1/07 (RLC #LFIL0000)

Schaffner #FN670-1.8/07

Corcom #1VR3

Note: Reference manufacturer's instructions when installing a line filter.

6. Long cable runs are more susceptible to EMI pickup than short cable runs. Therefore, keep cable runs as short as possible.
7. Switching of inductive loads produces high EMI. Use of snubbers across inductive loads suppresses EMI.
Snubber: RLC #SNUB0000.

WIRING CONNECTIONS

After the unit has been mechanically mounted, it is ready to be wired. All conductors should meet voltage and current ratings for each terminal. Also cabling should conform to appropriate standards of good installation, local codes and regulations. It is recommended that power supplied to the unit be protected by a fuse or circuit breaker. All wiring connections are made on removable plug-in terminal blocks. There is a separate terminal block for the bottom board (TBA) and optional top board (TBB). When wiring the unit, remove the terminal block and use the numbers on the label to identify the position number with the proper function. Strip the wire, leaving approximately 1/4" bare wire exposed (*stranded wires should be tinned with solder*). Insert the wire into the terminal and tighten down the screw until the wire is clamped tightly. Be sure all wires are clean and the connections are tight to ensure good conductivity. Each terminal can accept up to one 14-gauge, two 18-gauge or four 20-gauge wire(s). After the terminal block is wired, install it into the proper location on the PC board. Wire each terminal block in this manner.

POWER WIRING

Primary AC power is connected to TBA #1 and 2 (*marked VAC 50/60 HZ, located on the left hand side of the bottom terminal block*). To reduce the chance of noise spikes entering the AC line and affecting the indicator, the AC power should be relatively "clean" and within the specified $\pm 10\%$ variation limit. Drawing power from heavily loaded circuits or circuits which also power loads that cycle on and off, (*contactors, relays, motors, machinery, etc.*) should be avoided.

USER INPUT WIRING

User inputs (PGM.DIS., E1-CON, and optional E2-CON) are digital inputs that are active when connected to TBA #5 Common. Any form of mechanical switch, sinking open collector logic with less than 0.7 V saturation may be used. The use of shielded cable is recommended. Follow the Additional EMC Installation Guidelines for shield connection.

OUTPUT WIRING

RELAY CONNECTIONS

To prolong contact life and suppress electrical noise interference due to the switching of inductive loads, it is good installation practice to install a snubber across the contactor. Follow the manufacturer's instructions for installation.

Note: Snubber leakage current can cause some electro-mechanical devices to be held ON.

SIGNAL WIRING



Meter signal input common is not isolated from PGM.DIS, E1-CON, E2-CON, and +EXC. Maximum allowable 50 V can be present in the circuit that is being measured.

For Signal Sources Not Requiring Excitation:

Connect the “+” lead of the process signal to TBA #6, “+SIGNAL”, and the “-” lead of the signal to TBA #5, “COMM”. Regardless of the signal level of the process (4 to 20 mA or 10 to 50 mA, etc.), the indicator automatically adapts to the proper range. Refer to the transducer manufacturer’s data sheet supplied with the transducer for proper connections.

Two Wire Transducers Requiring Excitation:

Connect the “+” lead of the transducer to TBA #7, “+EXCITATION”, and the “-” lead to TBA #6, “+SIGNAL”. Refer to the transducer manufacturer’s data sheet supplied with the transducer for proper connections.

Note: The common of the excitation voltage is connected internally to “COMM” (TBA #5).

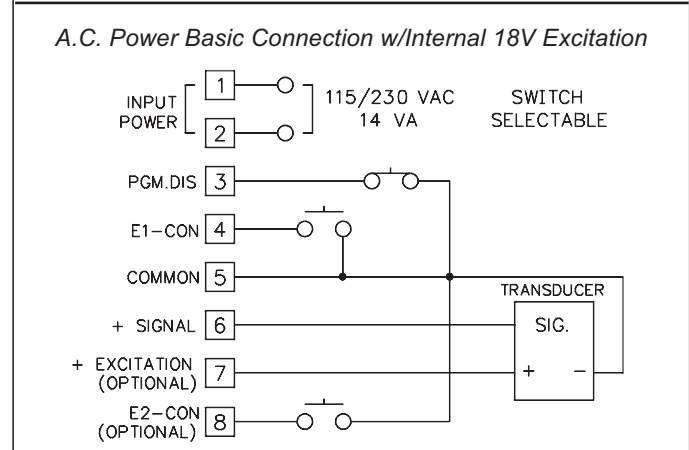
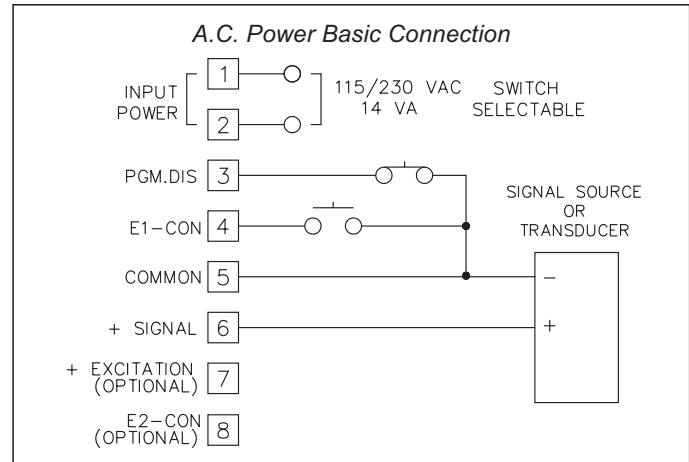

APPENDIX “B” - SPECIFICATIONS AND DIMENSIONS

- DISPLAY:** 6-digit, 0.56" (14.2 mm) High LED, minus sign displayed for negative values. Flashing display during totalizer overflow. “.....” displayed during input display out of range. “OLOLOL” displayed for input overload and “ULULUL” displayed for underload (negative overload).
- POWER REQUIREMENTS:**
Switch Selectable 115/230 VAC, $\pm 10\%$, 50/60 Hz, 14 VA
Isolation: 2300 Vrms for 1 min. to all inputs and outputs.
 Working Voltage: 300 V max., CATII
- CONTROLS:** Three front panel push buttons for modifying alarm values and indicator set-up. Two external inputs for disabling the front panel and controlling programmable functions.
- SIGNAL INPUT RANGE:** 0 to 50 mA DC (4 to 20 mA, 10 to 50 mA)
Input Common potential with respect to earth Common: 50 V max., CATI
- INPUT IMPEDANCE:** 10 Ω , 0.2 VDC @ 20 mA
Max. Input Current: 200 mA DC (continuous)
- ACCURACY AND RESOLUTION:**
Resolution: 1/40,000
Accuracy: $\pm (0.02\% \text{ of full scale} + 1 \text{ digit})$
Relative Humidity: Less than 85% RH
- PROGRAMMABLE DISPLAY READING RANGE:**
 -99,999 to 999,999
- READING RATE:** 2.5 readings/second
- RESPONSE TIME:** 2 seconds to settle for step input (increases with programmable digital filtering).
- NORMAL MODE REJECTION:** 40 dB at 50/60 Hz (may be improved by programmable digital filtering)
- COMMON MODE REJECTION:** 120 dB, DC to 50/60 Hz
- TOTALIZER:** Front panel button for input/total display select. External totalizer reset/enable. Programmable time-base, scale factor (0.001 to 100.000) and low-end cut-out. Max. response time = 0.2 sec.
- E1-CON & E2-CON:** External remote inputs which allow activation of various functions (reset total, peak indicator mode, trigger mode, etc.). $V_{IL} = 0.8 V_{MAX}$; $V_{IN} = 2.0 V_{MIN}$; Max. response time = 0.2 sec.
- ENVIRONMENTAL CONDITIONS:**
Operating Temperature Range: 0° to 50°C
Storage Temperature Range: -40° to 80°C
Span Temperature Coeff.: 100 PPM/oC max.; 40 PPM/°C typ.
Zero Temperature Coeff.: 1 $\mu\text{V}/^\circ\text{C}$
Operating and Storage Humidity: 85% max. relative humidity (non-condensing) from 0°C to 50°C.
Altitude: Up to 2000 meters
- EXCITATION (Optional):** Regulated 18 VDC @ 60 mA max. $\pm 5\%$

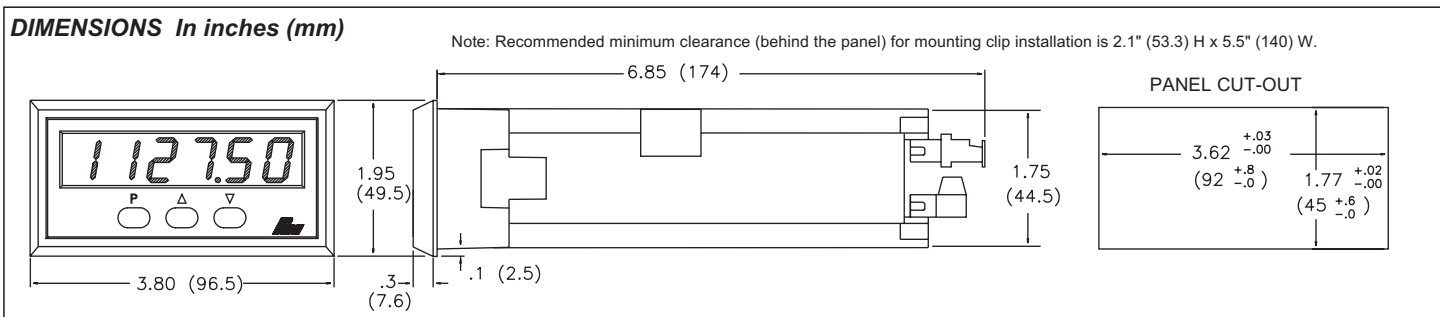

16. SERIAL COMMUNICATIONS (Optional):

Isolation To Signal Input Common: 500 Vrms for 1 min.

Working Voltage: 50 V max., CATI

Not isolated from all other commons.

Type: Bi-directional 20 mA current loop, 20 mA source provided on transmit loop. *(Powers up to 7 units in a loop with internal current source.)*

Baud Rate: programmable 300 to 2400

Maximum address: 99 *(Actual number in a single loop is limited by serial hardware specifications.)*

Data Format: 10 bit frame, Odd parity *(one start bit, 7 data bit, one odd parity bit, and one stop bit.)*

Serial Hardware Specifications:

SO - Output Transistor

Rating: $V_{max} = 30$ VDC, $V_{SAT} = 1 V_{MAX}$ @ 20 mA.

Note: This will allow up to 28 units max. in each loop.

SI - Input Diode Rating: $V_F = 1.25 V_{TYP}$; $1.5 V_{MAX}$

Note: The compliance voltage rating of the source must be greater than the sum of the voltage drops around the loop. (Typically a 30 VDC powered source would be capable of operating between 18 and 22 units in a loop.)

17. ALARMS (Optional):

Solid State: Two, isolated, sinking open collector NPN transistors acting in parallel with relays. $I_{max} = 100$ mA. $V_{SAT} = 1 V$ @ 100 mA max. $V_{MAX} = 30$ VDC.

Isolation To Signal Input Common: 500 Vrms for 1 min.

Working Voltage: 50 V max., CATI

Not isolated from all other commons.

Relays: Form C (2)

Isolation To Signal Input Common: 2300 Vrms for 1 min.

Working Voltage: 300 V max., CATII

Max. Rating: 5 Amps @ 120/240 VAC or 28 VDC *(resistive load)*, 1/8 hp @ 120 VAC *(inductive load)*.

Relay Life Expectancy: 100,000 cycles at max. rating. *(As load level decreases, life expectancy increases.)*

18. ANALOG OUTPUT (Optional): Digital scaling and offsetting.

Isolation To Signal Input Common: 500 Vrms for 1 min. Working

Working Voltage: 50 V max., CATI

Not isolated from all other commons.

4 to 20 mA:

Accuracy: 0.1% of full scale

Resolution: 12 bits

Compliance Voltage: 10 VDC *(500 Ω max. loop impedance)*

0 to 10 VDC:

Accuracy: $\pm(0.1\%$ of reading + 35 mV)

Resolution: 12 bits

Min. Load Resistance: 10 K Ω (1 μ A max.)

19. LINEARIZER/PEAK/VALLEY/TARE (Optional):

9-segment multiple slope scaling for non-linear inputs. Peak and Valley recording. Signal re-zero *(tare)*.

20. CERTIFICATIONS AND COMPLIANCES:

SAFETY

UL Recognized Component, File #E186643, UL3111-1, CSA 22.2, No. 1010-1

Recognized to U.S. and Canadian requirements under the Component Recognition program of Underwriters Laboratories, Inc.

Type 4 Enclosure rating (Face only), UL50

IECEE CB Scheme Test Certificate # UL2530-186643/USA,

CB Scheme Test Report #97RT10472-082198

Issued to Underwriters Laboratories, Inc.

IEC 1010-1, EN 61010-1: Safety requirements for electrical equipment for measurement, control, and laboratory use, Part 1.

IP65 Enclosure rating (Face only), IEC 529

ELECTROMAGNETIC COMPATIBILITY

Immunity to EN 50082-2

Electrostatic discharge	EN 61000-4-2	Level 2; 4 Kv contact ¹ Level 3; 8 Kv air
Electromagnetic RF fields	EN 61000-4-3	Level 3; 10 V/m ² 80 Mhz - 1 GHz
Fast transients (burst)	EN 61000-4-4	Level 4; 2 Kv I/O Level 3; 2 Kv power
RF conducted interference	EN 61000-4-6	Level 3; 10 V/rms 150 Khz - 80 MHz
Power frequency magnetic fields	EN 61000-4-8	Level 4; 30 A/m
Simulation of cordless telephones	ENV 50204	Level 3; 10 V/m 900 Mhz, ±5 MHz 200 Hz, 50% duty cycle

Emissions to EN 50081-2

RF interference	EN 55011	Enclosure class A Power mains class A
-----------------	----------	--

Notes:

1. Metal bezel of unit connected with ground lead from rear bezel screw to metal mounting panel.
 2. Self-recoverable loss of performance during EMI disturbance at 10 V/m:
Process and analog output signals may vary during EMI disturbance.
For operation without loss of performance:
Unit is mounted in a metal enclosure (Buckeye SM7013-0 or equivalent)
- Refer to the EMC Installation Guidelines section of the manual for additional information.

21. **CONSTRUCTION:** Die-cast metal front bezel that meets NEMA 4/IP65 requirements for indoor use when properly installed. Case body is black, high impact plastic (panel gasket and mounting clips included). Pollution Degree 2.
22. **CONNECTION:** Removable terminal blocks
23. **WEIGHT:** 1.2 lbs (0.5 kg)

APPENDIX "C" - LINEARIZER PROGRAM

The following computer program, written in GWBASIC, calculates two percentage tables required to linearize any non-linear relationship (eg. pH, flow, etc.) at programmable, error levels. One set represents percent of full scale for the input value and the other represents the corresponding percent of full scale for the display value. These values are then used to compute the actual input and display scaling points.

To use the program, copy it into any computer with GWBASIC installed. The program uses the relationship between the measured parameter and the display reading (*subroutine 10000*) for a square law device. Of course, ANY non-linear relationship can be substituted into this subroutine to yield the % of full scale input and % of full scale display. The program will prompt for (%) of full scale error relative to display readings. Increasing the conformity error decreases the number of linear slopes required to fit the function. The IMP can accommodate up to nine linear segments and it is generally desired to use all of them to minimize linearity error.

Note: Any non-linear function can be substituted for the equation at line 10010.

```
1 REM THIS PROGRAM WAS WRITTEN IN GWBASIC UNDER MS-DOS 3.3
2 REM THIS PROGRAM CALCULATES THE NUMBER OF LINEAR
  SEGMENTS REQUIRED
3 REM TO CURVE-FIT A GIVEN FUNCTION, SEEN IN LINE NUMBER
  10000.
6 REM THE PROGRAM COMPUTES THE RESULTS IN PER CENT(%) OF
  FULL SCALE PROCESS
7 REM VALUE AND FULL SCALE DISPLAY VALUE. MULTIPLY THE PER
  CENT VALUE TIMES
8 REM THE FULL SCALE PROCESS AND DISPLAY VALUES TO OBTAIN
  EXACT SCALING
9 REM POINTS FOR THE IMP LINEARIZING FUNCTION.
10 CLS
15 PRINT "  CURVE FITTING PROGRAM"
16 PRINT ""
30 DIM PA(30)
40 DIM DA(30)
50 INPUT "ENTER CURVE FITTING ERROR (%) >";E
60 P = 10000
70 GOSUB 10000
75 CR=D/P
```

```
80 ER=D*E*.01
110 CLS
111 SG=SG+1
112 PRINT "  CALCULATING LINEAR SEGMENT ";SG
115 IF P2>=10000 THEN A=1:GOTO 1000
117 P2=P2+10
130 P=P1
140 GOSUB 10000
150 D1=D
170 P=P2
180 GOSUB 10000
190 D2=D
210 M=(D2-D1)/(P2-P1)
220 B=D1-(P1*M)
240 PT=P1
245 AD=(P2-P1)/6
250 PT=PT+AD
260 P=PT
270 GOSUB 10000
280 DT=D
290 DT1=(PT*M)+B
310 IF ABS(DT1-DT)>ER THEN 500
320 IF PT <P2 THEN GOTO 250
330 GOTO 115
500 P2=P2+10
510 D2=(P2*M)+B
515 P=P2
520 GOSUB 10000
550 IF ABS(D-D2)<ER THEN 500
1000 PA(SG)=P2/100
1020 DA(SG)=D2/CR/100
1200 P1=P2
1210 D1=D2
1216 IF A< >1 THEN GOTO 110
2000 CLS
2010 PRINT "NUMBER OF LINEAR SEGMENTS = ";SG
2012 PRINT "CURVE FITTING ERROR (%) = ";E
2015 PRINT ""
```

APPENDIX "C" - LINEARIZER PROGRAM (Cont'd)

```
2016 PRINT "DISPLAY VALUES   PROCESS VALUES"
2017 PRINT "(% OF RANGE)      "; "(% OF RANGE)"
2018 PRINT ""
2019 FOR I=0 TO SG
2020 PRINT USING "###.##";DA(I);
2022 PRINT "          ";
2025 PRINT USING "###.##";PA(I)
2030 NEXT I
2040 END
10000REMD=DISPLAY(Y),P=PROCESS(X)
10010 D=SQR(P)
10020 RETURN
```

] Square Root
] Extraction
] Formula

APPENDIX “D” - TROUBLESHOOTING GUIDE

The majority of all problems with the indicator can be traced to improper connections or improper programming set-ups. Be sure all connections are clean and tight and check the programming set-ups for correct data.

For further technical assistance, contact technical support at the numbers listed on the back cover of the instruction manual.

PROBLEM	POSSIBLE CAUSE	REMEDIES
NO DISPLAY	1. Power off, improperly connected, or brown-out.	1a. Check wiring. b. Verify power.
“PPPPPP” IN DISPLAY	1. Program data error.	1. Press “P” and Check data set-ups.
FLASHING DISPLAY	1. Totalizer overflow.	1. Reset totalizer.
“.....” IN DISPLAY	1. Input display out of range. 2. Loss of data set-ups.	1a. Check unit scaling. b. Check for electrical disturbance. 2a. Check data set-ups. b. Check for electrical disturbance. c. Disconnect and reconnect power.
DISPLAY WANDERS	1. Loss of data set-ups.	1a. Check data set-ups. b. Disconnect and reconnect power. c. Check for electrical disturbance.
JITTERY DISPLAY	1. Electrical “Noise” in process or signal lines. 2. Process inherently unstable.	1a. Increase digital filtering. b. Increase display rounding increment. c. Re-route signal wires. 2. Dampen process to eliminate oscillations.
“ULULUL” IN DISPLAY	1. Input Underload (negative overload).	1. Check input levels.
“OLOLOL” IN DISPLAY	1. Input overload.	1. Check input levels.

APPENDIX “E” - PROGRAMMABLE FUNCTIONS

Programming of the indicator is divided into modular steps. Each module is a short sequence of data entries. The front panel buttons “UP” and “DOWN”, (shown as “arrows” on the front panel) are used to change the data and set-ups, while the “P” button is used to *save* or *enter* the data. After pressing “P” which gains entry into the programming mode, the programming modules are identified by the message “Pro” and a number in the display. “UP” and “DOWN” are used to select the desired programming module and “P” is used to enter it. All of the subsequent programming steps follow the same procedure. The rear terminal labeled “PGM. DIS.” must be ungrounded to gain access to programming. The following table lists the programming steps.

“Pro 0” - RETURN TO MEASUREMENT MODE

“Pro 1” - SCALE UNIT BY APPLYING SIGNAL

“dECPNt”	– Enter decimal point for scaled display
“round”	– Enter rounding factor and trailing zeros for scaled display
“SCALE”	* *
“dSP 1”	Enter display reading for scaling point #1
“INP 1”	Apply signal level for scaling point #1
“dSP 2”	Enter display reading for scaling point #2
“INP 2”	Apply signal level for scaling point #2
“SEGT”	– *

“Pro 2” - SCALE UNIT BY KEY-IN SIGNAL LEVEL

“dECPNt”	– Enter decimal point for scaled display
“round”	– Enter rounding factor and trailing zeros for scaled display
“SCALE”	– *
“dSP 1”	– Enter display reading for scaling point #1
“INP 1”	– Enter signal level for scaling point #1
“dSP 2”	– Enter display reading for scaling point #2
“INP 2”	– Enter signal level for scaling point #2
“SEGT”	– *

* Entire sequence for this modular step is not shown (see respective programming module for further details).

** This sequence may be subject to being locked-out due to other programmed sequences.

“Pro 3” - PROGRAM FUNCTIONS ACCESSIBLE WITH FRONT PANEL LOCKOUT ENGAGED

“dSP AL”	– Enable display alarms
“ENT AL”	– Enable enter alarms **
“dSPHYS”	– Enable display hysteresis
“ENTHYS”	– Enable enter hysteresis **
“rSt AL”	– Enable reset latched alarms
“dSPbUF”	– Enable display of peak/valley readings
“rStbUF”	– Enable reset of peak/valley readings **
“SELdSP”	– Enable switching display between input and total
“rSttOt”	– Enable reset total
“tArE”	– Enable re-zero (tare) of input signal

“Pro 4” - PROGRAM DIGITAL FILTERING AND REMOTE INPUT FUNCTION

“FILTER”	– Enter level of digital filtering
0	– no digital filtering
1	– normal filtering
2	– increased filtering
3	– maximum filtering
“E1-CON”	– Enter function of remote input
0	– re-zero input
1	– reset total
2	– reset and gate totalizer
3	– gate totalizer
4	– display hold
5	– reset peak/valley
6	– reset peak and start peak indicator
7	– reset valley and start valley indicator
8	– reset latched alarms
9	– reset all alarms
10	– toggle display between input and total
11	– re-zero input and totalize the tared values
12	– display hold with tare
13	– Instrument reading synchronization
14	– print request
“E2-CON”	– Same functions as E1-CON

APPENDIX “E” - PROGRAMMABLE FUNCTIONS (Cont’d)

“Pro 5” - PROGRAM TOTALIZER

- “dECPNt” – Enter decimal point for totalizer
- “tbASE” – Enter time base
 - 0 – second
 - 1 – minute
 - 2 – hour
- “SCLFAC” – Enter multiplying scale factor
- “Lo-cut” – Enter low-signal cut-out

“Pro 6” - PROGRAM ALARMS

- “trAc” – Enable alarm value tracking
- “dISP” – Enable display alarm annunciators
- “LAtC-1” – Enable alarm #1 latching
- “ASN-1” – Enter alarm #1 trigger source (input or total)
- “AL-1” – Enter alarm #1 value
- “HYS-1” – Enter hysteresis value for alarm #1
- “Act-1” – Enter alarm #1 action (high or low)
- “LAtC-2” – Enable alarm #2 latching
- “ASN-2” – Enter alarm #2 trigger source (input or total)
- “AL-2” – Enter alarm #2 value
- “HYS-2” – Enter hysteresis value for alarm #2
- “Act-2” – Enter alarm #2 action (high or low)

“Pro 7” - PROGRAM SERIAL COMMUNICATIONS

- “bAud” – Enter baud rate
- “AddrES” – Enter loop address number (0-99)
- “Print” – Enter print function, or “P” command function through Serial Option
 - 0 – input
 - 1 – input, peak/valley, and tare
 - 2 – input and alarms
 - 3 – input, peak/valley, alarms, hysteresis, and tare
 - 4 – total
 - 5 – input, total
 - 6 – input, total, peak/valley, and tare
 - 7 – total and alarms
 - 8 – input, total and alarms
 - 9 – input, total, peak/valley, alarms, hysteresis, and tare
- “FULL” – Enable complete or abbreviated printing

“Pro 8” - PROGRAM RE-TRANSMITTED ANALOG OUTPUT

- “ASIN” – Select source of analog output (input or total)
- “AN-Lo” – Enter 4 mA or 0 VDC display value
- “AN-HI” – Enter 20 mA or 10 VDC display value

“Pro 9” - SERVICE OPERATIONS *(Protected by access codes)*

- “Code 39” – Serial hardware (loop-back) test
- “Code 48” – Basic input calibration
- “Code 66” – Reset programming to factory configuration

APPENDIX "F" - USERS PROGRAMMING VALUES CHART

PROGRAM MODULE #1

Scaled By Signal Method

dECPNT _____
round _____
SCALE _____
dSP 1 _____
INP 1 _____
dSP 2 _____
INP 2 _____

Additional scaling points are **NOT** necessary,
unless multi-segment linearization is required.

dSP 3 _____
INP 3 _____
dSP 4 _____
INP 4 _____
dSP 5 _____
INP 5 _____
dSP 6 _____
INP 6 _____
dSP 7 _____
INP 7 _____
dSP 8 _____
INP 8 _____
dSP 9 _____
INP 9 _____

PROGRAM MODULE #2

Scaled By Signal Method

dECPNT _____
round _____
SCALE _____
dSP 1 _____
INP 1 _____
dSP 2 _____
INP 2 _____

Additional scaling points are **NOT** necessary,
unless multi-segment linearization is required.

dSP 3 _____
INP 3 _____
dSP 4 _____
INP 4 _____
dSP 5 _____
INP 5 _____
dSP 6 _____
INP 6 _____
dSP 7 _____
INP 7 _____
dSP 8 _____
INP 8 _____
dSP 9 _____
INP 9 _____

APPENDIX "F" - USERS PROGRAMMING VALUES CHART

PROGRAM MODULE #3

Front Panel Lockout

dSP AL _____
Ent AL _____
dSPHYS _____
ENTHYS _____
rSt AL _____
dSPbUF _____
rStbUF _____
SELdSP _____
RSttOt _____
tArE _____

PROGRAM MODULE #4

Digital Filter & Remote Input Function

FILTER _____
E1-CON _____
E2-CON _____

PROGRAM MODULE #5

Integrator/Totalizer

dECPNt _____
tdASE _____
SCLFAC _____
Lo-cut _____

PROGRAM MODULE #6

Alarms

trAC _____
dISP _____
LAtC-1 _____
ASN-1 _____
AL-1 _____
HyS-1 _____
Act-1 _____
LAtC-2 _____
ASN-2 _____
AL-2 _____
HyS-2 _____
Act-2 _____

PROGRAM MODULE #7

Communications

bAud _____
AddrES _____
Print _____
FULL _____

PROGRAM MODULE #8

Analog Output

ASIN _____
AN-Lo _____
AN-HI _____

APPENDIX “G” - ORDERING INFORMATION

MODEL NO.	DESCRIPTION	+18 VDC EXCITATION	TOTALIZER/ LINEARIZER PEAK/VALLEY TARE/E2CON	DUAL ALARMS	SERIAL OUTPUT	ANALOG OUTPUT	PART NUMBERS FOR AVAILABLE SUPPLY VOLTAGES
							115/230 VAC
IMP	Intelligent Process Meter with 0 to 50 mA DC Signal Input (4-20 mA DC, 10-50 mA DC)	No	No	No	No	No	IMP20060
		Yes	No	No	No	No	IMP20160
		Yes	No	Yes	No	No	IMP20162
		Yes	Yes	No	No	No	IMP23160
		Yes	Yes	No	Yes	No	IMP23161
		Yes	Yes	Yes	No	No	IMP23162
		Yes	Yes	No	No	4 to 20 mA	IMP23163
		Yes	Yes	Yes	Yes	4 to 20 mA	IMP23167
Yes	Yes	Yes	Yes	0 to 10 VDC	IMP23169		
For information on Pricing, Enclosures, & Panel Mount Kits refer to the RLC catalog or contact your local RLC distributor.							

LIMITED WARRANTY

The Company warrants the products it manufactures against defects in materials and workmanship for a period limited to one year from the date of shipment, provided the products have been stored, handled, installed, and used under proper conditions. The Company's liability under this limited warranty shall extend only to the repair or replacement of a defective product, at The Company's option. The Company disclaims all liability for any affirmation, promise or representation with respect to the products.

The customer agrees to hold Red Lion Controls harmless from, defend, and indemnify RLC against damages, claims, and expenses arising out of subsequent sales of RLC products or products containing components manufactured by RLC and based upon personal injuries, deaths, property damage, lost profits, and other matters which Buyer, its employees, or sub-contractors are or may be to any extent liable, including without limitation penalties imposed by the Consumer Product Safety Act (P.L. 92-573) and liability imposed upon any person pursuant to the Magnuson-Moss Warranty Act (P.L. 93-637), as now in effect or as amended hereafter.

No warranties expressed or implied are created with respect to The Company's products except those expressly contained herein. The Customer acknowledges the disclaimers and limitations contained herein and relies on no other warranties or affirmations.

IMP / IM - O 6/02
DRAWING NO. LP0183

Red Lion Controls
20 Willow Springs Circle
York PA 17402
Tel +1 (717) 767-6511
Fax +1 (717) 764-0839

Red Lion Controls BV
Basicweg 11b
NL - 3821 BR Amersfoort
Tel +31 (0) 334 723 225
Fax +31 (0) 334 893 793