

**INTERNATIONAL HEADQUARTERS**  
20 Willow Springs Circle, York, Pa. 17402, (717) 767-6511 FAX: (717) 764-0839  
Web site- <http://www.redlion-controls.com> E-mail- [sales@redlion-controls.com](mailto:sales@redlion-controls.com)

**EUROPEAN HEADQUARTERS**  
892 Plymouth Road, Slough, Berkshire SL1 4LP  
ENGLAND +44 1753 696888 FAX: +44 1753 696339

## MODEL IMI - APOLLO 6 DIGIT INTELLIGENT METER FOR RATE INPUTS

- 6-DIGIT, 0.56" (14.2 mm) HIGH RED LED DISPLAY
- ACCEPTS INPUT RATES UP TO 50 KHz
- SECONDARY DISPLAY INDICATES TOTALIZATION or EFFICIENCY
- 0.01% ACCURACY
- PEAK/VALLEY INDICATION & MEMORY
- PROGRAMMABLE FRONT PANEL LOCK-OUT
- SENSOR EXCITATION SUPPLY
- DUAL ALARM RELAY OUTPUTS (Optional)
- BI-DIRECTIONAL SERIAL COMMUNICATIONS (Optional)
- 4 to 20 mA or 0 to 10 VDC ANALOG OUTPUT (Optional)



- NEMA 4/IP65 SEALED METAL FRONT BEZEL



### GENERAL DESCRIPTION

The Apollo Intelligent Meter for Digital Rate Inputs (IMI) accepts frequencies up to 50 KHz which can be scaled to any desired engineering units. The sensor input is user configurable and allows for a wide selection of compatible sensors. The adjustable minimum and maximum update times provide optimal display response at any input frequency.

The IMI provides two display functions in a single package. The display can indicate the input rate and then be toggled to display either totalization or efficiency. The max. display for all functions is 999,999. The totalizer features independent scaling and a low signal cut-out to suit a variety of applications. The efficiency feature can display the input rate in percent of target (process efficiency). Additionally, nine segments can easily be programmed to linearize transducers with non-linear outputs, such as square law devices.

The indicator features a choice of two different scaling procedures for the rate display, which greatly simplifies initial set-up. English-style display prompts and front panel buttons aid the operator in set-up and operation. A front panel programmable lock-out menu used with the program disable input protects set-up data and guarantees no unwanted changes occur during operation. Programmable digital filtering enhances the stability of the reading. Programmable remote inputs "E1-CON" and "E2-CON" can be used to control a variety of functions, such as totalizing, alarm control, display hold or triggered input. All set-up data is stored in nonvolatile memory.

Peak/valley (max/min) indication is included and is easily recalled and controlled by either the front panel buttons or a remote input. The Peak/Valley buffers can be assigned to either the rate or efficiency display and all readings are retained at power-down.

Optional dual relays that operate in parallel with solid state outputs are fully programmable to operate in a wide variety of modes to suit many control or alarm applications.

The optional 20 mA current loop, half-duplex serial communications, provides computer and printer interfacing to extend the capabilities of the indicator. More than one unit can be connected in the loop with other RLC products which have serial communications capabilities.

An optional 4 to 20 mA or 0 to 10 VDC analog output can be scaled by the user to interface with a host of recorders, indicators and controllers. The

indicator has several built-in diagnostic functions to alert operators of most malfunctions. Extensive testing of noise interference mechanisms and full burn-in make the indicator extremely reliable in industrial environments. The die-cast front bezel meets NEMA 4/IP65 requirements for washdown applications, when properly installed. Plug-in style terminal blocks simplify installation and wiring change-outs.

### SAFETY SUMMARY

All safety related regulations, local codes and instructions that appear in the manual or on equipment must be observed to ensure personal safety and to prevent damage to either the instrument or equipment connected to it. If equipment is used in a manner not specified by the manufacturer, the protection provided by the equipment may be impaired.

Do not use this unit to directly command motors, valves, or other actuators not equipped with safeguards. To do so, can be potentially harmful to persons or equipment in the event of a fault to the unit.

### SPECIFICATIONS

- DISPLAY:** 6-digit, 0.56" (14.2 mm) High Red LED, programmable decimal points, maximum display 999,999. Flashing display during totalizer overflow. "—" displayed during rate/efficiency display out of range.
- POWER REQUIREMENTS:**  
**A.C. Power:** Switch selectable 115/230 VAC,  $\pm 10\%$ , 50/60 Hz, 14 VA  
**D.C. Power:** 10 to 30 VDC, 9watts max., isolated to 300 Vp.
- CONTROLS:** Three front panel push buttons for modifying alarm values and indicator set-up. Three external inputs; one for disabling the front panel, two for programmable function inputs.
- SIGNAL INPUT:** Switch selectable to accept signals from a wide variety of sensors.  
**Max. Input Frequency:** 50 KHz, 50% Duty Cycle.  
**Max. Input Voltage & Current:**  
 With NPN O.C. switch OFF;  $\pm 50$  V peak,  $\pm 5$  mA.  
**Input Impedance:** With MAG. PKUP. & NPN O.C. switches OFF; 1 M $\Omega$ .

### DIMENSIONS "In inches (mm)"

Note: Recommended minimum clearance (behind the panel) for mounting clip installation is 2.1" (53.3)H x 5.5" (140)W.

PANEL CUT-OUT

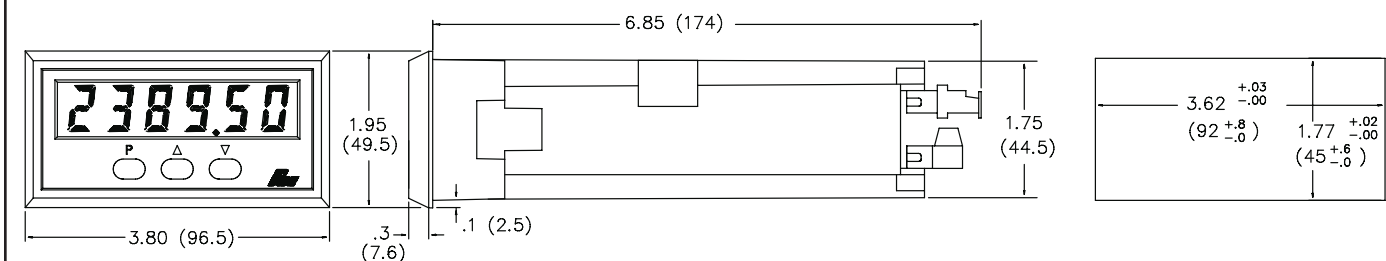

## SPECIFICATIONS (Cont'd)

### 4. SIGNAL INPUT: (Cont'd)

#### SWITCHES:

**MAG PKUP:** Connects a 0.1  $\mu$ F input damping capacitor.

**Sensitivity:** 125 mV peak (typical @ 12 VDC)

**Hysteresis:** 30 mV

**Input Impedance:** 26.5 K $\Omega$  @ 60 Hz

**Max. Input Vltage:**  $\pm$ 50 V peak

**LOGIC:** Sets input trigger level.

**Trigger Level:** +2.5V with 30 mV hysteresis.

**NPN O.C.:** Provides internal 3.9 K $\Omega$  pull-up resistor to +12 VDC.

$I_{SNK} = 3$  mA MAX @ 12 VDC

$V_{MAX}$  IN = 28 VDC

### 5. DISPLAY COMBINATIONS: Rate/Total or Rate/Efficiency.

### 6. RATE/EFFICIENCY:

**Accuracy:** 0.01%  $\pm$ 1 digit

**Min. Input Frequency:** 0.01 Hz

**Programmable Update Time Range:** 0.2 secs to 100.0 secs

### 7. TOTALIZER: Programmable time-base, scale factor (0.001 to 100.000) and low-end cutout. Max. response time 0.2 secs.

### 8. PROGRAM DISABLE (PGM.DIS.): Used with programmable lockout menus to limit operator entry when active. Connect to common (TBA #7) to activate.

### 9. E1-CON & E2-CON: External remote inputs which allow activation of various functions (reset total, peak indicator mode, trigger mode, etc).

$V_{IL} = 0.8 V_{MAX}$ ;  $V_{IH} = 2.0 V_{MIN}$ ; Response Time = 0.2 sec max.

### 10. ENVIRONMENTAL CONDITIONS:

**Operating Temperature:** 0 to 50°C

**Storage Temperature:** -40 to 80°C

**Operating and Storage Humidity:** 85% max. (non-condensing) from 0°C to 50°C.

**Altitude:** Up to 2000 meters

### 11. DC OUT: +12 VDC $\pm$ 25% @ 60 mA max.

### 12. SERIAL COMMUNICATIONS (Optional):

**Type:** Bi-directional 20 mA current loop, 20 mA source provided on transmit loop. (Powers up to 7 units in a loop with internal current source).

**Baud Rate:** programmable 300 to 9600

**Maximum address:** 99 (Actual number in a single loop is limited by serial hardware specifications).

**Data Format:** 10 bit frame, Odd parity (one start bit, 7 data bit, one odd parity bit, and one stop bit).

#### Serial Hardware Specifications:

**SO - Output Transistor Rating:**  $V_{MAX} = 30$  VDC,  $V_{SAT} = 1 V_{MAX}$  at 20 mA.

Note: This will allow up to 28 units max. in each loop.

**SI - Input Diode Rating:**  $V_F = 1.25$  V TYP;  $1.5 V_{MAX}$

Note: The compliance voltage rating of the source must be greater than the sum of the voltage drops around the loop. (Typically a 30 VDC powered source would be capable of operating between 18 and 22 units in a loop.)

### 13. ALARMS (Optional):

**Response Time:** 0.2 sec min.

**Solid State:** Two, isolated, sinking open collector NPN transistors acting in parallel with relays.

$V_{CE} = 1V_{MAX}$  @ 100 mA max.;  $V_{OH} = 30$  VDC max.

#### Relays:

**Type:** Form C (2)

**Max. Rating:** 5 Amps @ 120/240 VAC or 28 VDC (resistive load), 1/8 HP @ 120 VAC (inductive load). The operate time is 5 msec nominal and the release time is 3 msec nominal.

**Relay Life Expectancy:** 100,000 cycles at Max. load Rating. (As load level decreases, life expectancy increases.)

### 14. ANALOG OUTPUT (Optional):

**4 to 20 mA:** Digital scaling and offsetting within 4 to 20 mA range.

**Accuracy:** 0.1% of full scale

**Resolution:** 12 bits

**Compliance Voltage:** 10 VDC (500  $\Omega$  max. loop impedance)

**0 to 10 VDC:** Digital scaling and offsetting within 0 to 10 VDC range.

**Accuracy:**  $\pm$ (0.1% of reading +35 mV)

**Resolution:** 12 bits

**Min. Load Resistance:** 10 K $\Omega$  (1 mA max.)

### 15. LINEARIZER/PEAK/VALLEY: 9-segment multiple slope scaling for non-linear inputs. Peak and Valley recording.

### 16. CERTIFICATIONS AND COMPLIANCES:

#### EMC EMISSIONS:

Meets EN 50081-2: Industrial Environment.

CISPR 11 Radiated and conducted emissions

#### EMC IMMUNITY:

Meets EN 50082-2: Industrial Environment.

ENV 50140 - Radio-frequency radiated electromagnetic field<sup>1</sup>

ENV 50141 - Radio-frequency conducted electromagnetic field

EN 61000-4-2 - Electrostatic discharge (ESD)<sup>2</sup>

EN 61000-4-4 - Electrical fast transient/burst (EFT)

EN 61000-4-8 - Power frequency magnetic field

#### Notes:

##### 1. Units with Analog Output Option

Permissible loss of performance during EMI disturbance at 10V/m.

Analog Output Deviation: Less than 27% of full scale

For operation without loss of performance:

a. Install power line filter, RLC #LFIL0000 or equivalent.

b. Install unit in a Buckeye SM 7013-0 enclosure or equivalent.

c. Install all I/O cables connecting to the unit in metal conduit that is connected to the enclosure at one end, and earth ground at the opposite end.

2. Metal bezel of unit connected with ground lead from rear bezel screw to metal mounting panel. Mounting panel connected to earth ground (protective earth).

Refer to the EMC Installation Guidelines section of the manual for additional information.

17. **CONSTRUCTION:** Die-cast metal front bezel that meets NEMA 4/IP65 requirements for indoor use when properly installed. Installation Category II, Pollution Degree 2. Case body is black, high impact plastic (panel gasket and mounting clips included).

18. **CONNECTION:** Removable terminal blocks.

19. **WEIGHT:** 1.2 lbs (0.5 kg)

## SECONDARY DISPLAY TOTALIZATION OR EFFICIENCY

The secondary display can be programmed to indicate either totalization or input rate efficiency.

The Totalizer totals (adds) input pulses and displays the result according to the programmable time base and scale factor values. A low-end cutout can be programmed to stop totalization if desired. The Efficiency display will indicate the current percentage of the input signal as compared to the programmed target value.

The decimal point position of the totalizer or efficiency display is programmed independent of the input rate signal. The totalizer may be reset via a remote input (E1-CON or E2-CON) or by the front panel buttons. At loss of power to the indicator, the contents of the totalizer are saved.

## LINEARIZER/PEAK & VALLEY DETECTION

The linearizer feature is a series of programmable scaling points that are used to construct linear segments to linearize the input signal. A maximum of nine segments are available.

The peak/valley detection feature will indicate and record the lowest reading (valley) and the highest reading (peak), automatically, for later recall. This information is valuable in monitoring the limits of the process over any length of time since these values are stored at power-down to span over shifts, days, etc. An external input can be programmed to reset or engage the unit into a peak/valley reading indicator. Additionally, the peak and valley can be viewed and reset from the front panel, if so programmed.

## ISOLATED SERIAL COMMUNICATIONS OPTION

The serial communication option is a half-duplex, two-way 20 mA current loop that can be connected to a printer, a computer, a terminal, or a controller to suit many data-polling or automatic operation applications. The indicator responds to a host of commands, which include change alarm value, reset totalizer, and transmit input rate value. Two loops are required for all hook-ups, a transmit loop and a receive loop. An internal 20 mA source is provided with the serial option. Additionally, multiple units and other Red Lion Controls instruments can be serially addressed, with a maximum address capability of 99 units.

## ISOLATED ALARM OPTION

The alarm option consists of an additional printed circuit board with nine terminals. Six of these are for the two Form-C relays and the other three are the two open collector transistors, which act in parallel with the relays. The two alarms are completely independent with programmable values, hysteresis (deadband), high or low acting, ON/OFF delay, auto or manual reset, triggering from input rate or total/efficiency, and tracking one another, if desired. If the alarms are programmed to latch (manual reset), then they will have to be reset either by the front panel buttons or remote input (E1-CON or E2-CON). The alarms can be made to activate external alarms, control valves, etc.

Alarm #1 can be made to track Alarm #2 by enabling alarm tracking. This is useful in alarm set-ups where a pre-warning control activates before a second alarm shuts off the process when tracking is programmed. Changing the shut-off trip value (Alarm #2) automatically changes Alarm #1 so that the offset between Alarm #2 and Alarm #1 remains the same.

# ISOLATED RE-TRANSMITTED ANALOG OUTPUT OPTION

## 4 to 20 mA

The re-transmitted analog output option transmits a digitally programmable 4 to 20 mA current to drive chart recorders, remote indicators and controllers. The compliance is 10 VDC. Non-standard current ranges within the 4 to 20 mA range can be supported by calculating the slope and intercept of the display/output and calculating the required display values at 4 mA and 20 mA.

## 0 to 10 VDC

The re-transmitted analog output option transmits a digitally programmable 0 to 10 VDC output signal to drive chart recorders, remote indicators and controllers. Non-standard voltage ranges within the 0 to 10 VDC range can be supported by calculating the slope and intercept of the display/output and calculating the required display values at 0 VDC and 10 VDC.

### PROGRAMMABLE FUNCTIONS

Programming of the indicator is divided into modular steps. Each module is a short sequence of data entries. The front panel "UP" and "DOWN" buttons (shown as "arrows" on the front panel) are used to change the data and set-ups, while the "P" button is used to save or enter the data. After pressing "P", the user gains entry into the programming mode. The programming modules are identified by the message "Pro" and a module number in the display. "UP" and "DOWN" are used to select the desired programming module and "P" is used to enter it. All of the subsequent programming steps follow the same procedure. The rear terminal labeled "PGM.DIS." must be inactive (ungrounded) to gain access to programming. The following table lists the programming steps.

#### "Pro 0" - RETURN TO MEASUREMENT MODE

#### "Pro 1" - SCALE UNIT BY APPLYING SIGNAL

- "dECPnt" - Enter decimal point for scaled input display
- "round" - Enter rounding factor and trailing zeros for scaled input display
- "Lo-udt" - Enter low update time for rate display updates
- "Hi-udt" - Enter high update time for rate display updates
- "SCALE" -  $\diamond$
- "dSP 1" - Enter display reading for scaling point #1
- "rAtE 1" - Apply rate value for scaling point #1
- "SEgt" -  $\diamond$

#### "Pro 2" - SCALE UNIT BY KEY-IN SIGNAL LEVEL

- "dECPnt" - Enter decimal point for scaled display
- "round" - Enter rounding factor and trailing zeros for scaled display
- "Lo-udt" - Enter low update time for rate display updates
- "Hi-udt" - Enter high update time for rate display updates
- "SCALE" -  $\diamond$
- "dSP 1" - Enter display reading for scaling point #1
- "rAtE 1" - Enter rate value for scaling point #1
- "SEgt" -  $\diamond$

#### "Pro 3" - PROGRAM FUNCTIONS ACCESSIBLE WITH FRONT PANEL LOCKOUT ENGAGED

- "dSP AL" - Enable display alarms
- "ENT AL" - Enable enter alarms \*
- "dSPHYS" - Enable display hysteresis
- "ENTHYS" - Enable enter hysteresis \*
- "rSt AL" - Enable reset latched alarms
- "dSPbUF" - Enable display of peak/valley readings
- "rStbUF" - Enable reset of peak/valley readings \*
- "SEldSP" - Enable switching display between input and total/efficiency
- "rSttOt" - Enable reset total \*

#### "Pro 4" - PROGRAM DIGITAL FILTERING AND REMOTE INPUT (E1-CON & E2-CON) FUNCTION

- "FILter" - Enter level of digital filtering
  - 0 - no digital filtering
  - 1 - normal level
  - 2 - increased level
  - 3 - maximum level
- "E1-CON" - Enter function of remote input
  - 0 - Re-start measurement time for input
  - 1 - Reset total
  - 2 - Reset and gate totalizer
  - 3 - Gate totalizer
  - 4 - Display hold
  - 5 - Reset peak/valley
  - 6 - Reset peak and start peak indicator
  - 7 - Reset valley and start valley indicator
  - 8 - Reset latched alarms
  - 9 - Reset all alarms
  - 10 - Toggle display between input rate and total or efficiency
  - 11 - Input rate functions as a triggered rate meter
  - 12 - Print request
- "E2-CON" < > E2-CON has the same programmable functions as E1-CON.

#### "Pro 5" - PROGRAM SECOND DISPLAY AS TOTALIZER OR EFFICIENCY TOTALIZER

- "dISp" - Select desired display (Total or Efficiency)
  - TOTALIZER
- "dECPnt" - Enter decimal point for totalizer
- "tbASE" - Enter time base
  - 0 - Divide by 1 (second)
  - 1 - Divide by 60 (minute)
  - 2 - Divide by 3600 (hour)
- "SCLFAC" - Enter multiplying scale factor
- "Lo-cut" - Enter low-signal cut out
  - EFFICIENCY
- "ASNbUF" - Assign peak/valley buffers
- "dECPnt" - Enter decimal point for efficiency
- "100Pct" - Enter value for desired 100 percent target value

#### "Pro 6" - PROGRAM ALARMS

- "trAc" - Enable alarm value tracking
- "dISp" - Enable display alarm annunciators
- "LAtC-1" - Enable alarm #1 latching
- "ASN-1" - Enter alarm #1 trigger source (input or total/eff.)
- "AL-1" - Enter alarm #1 value
- "HYS-1" - Enter hysteresis value for alarm #1
- "Act-1" - Enter alarm #1 action (high or low)
- "OndEL1" - Enable delay ON action for alarm #1
- "OFdEL1" - Enable delay OFF action for alarm #1 (disabled if delay ON is selected) \*
- "dELAY1" - Enter delay time value
- "LAtC-2" - Enable alarm #2 latching
- "ASN-2" - Enter alarm #2 trigger source (input or total/eff.)
- "AL-2" - Enter alarm #2 value
- "HYS-2" - Enter hysteresis value for alarm #2
- "Act-2" - Enter alarm #2 action (high or low)
- "OndEL2" - Enable delay ON action for alarm #2
- "OFdEL2" - Enable delay OFF action for alarm #2 (disabled if delay ON is selected) \*
- "dELAY2" - Enter delay time value

#### "Pro 7" - PROGRAM SERIAL COMMUNICATIONS

- "bAud" - Enter baud rate
- "AddrES" - Enter loop address number (0-99)
- "Print" - Enter print function
  - "0" - rate
  - "1" - rate, peak, valley
  - "2" - rate, alarm 1, alarm 2
  - "3" - rate, alarm 1, alarm 2, hysteresis 1, hysteresis 2, peak, valley
  - "4" - totalizer/efficiency
  - "5" - rate, totalizer/efficiency
  - "6" - rate, totalizer/efficiency, peak, valley
  - "7" - totalizer/efficiency, alarm 1, alarm 2
  - "8" - rate, totalizer/efficiency, alarm 1, alarm 2, hysteresis 1, hysteresis 2, peak, valley
  - "9" - rate, totalizer/efficiency, alarm 1, alarm 2, hysteresis 1, hysteresis 2, peak, valley
- "FULL" - Enable/Disable abbreviated printing

#### "Pro 8" - PROGRAM RE-TRANSMITTED ANALOG OUTPUT

- "ASIN" - Select source of analog output (input or total/eff.)
- "AN-Lo" - Enter 4 mA or 0 VDC display value
- "AN-HI" - Enter 20 mA or 10 VDC display value

#### "Pro 9" - FACTORY SERVICE OPERATIONS

(Protected by access codes)

$\diamond$  - Entire sequence for this modular step is not shown (see manual for further details).

\* - This sequence may be locked-out due to other programmed sequences.

## PROGRAMMING EXAMPLE

An IMI is used to monitor web speed of a textile machine. A display of the web speed in FPM and efficiency is also desired. Underspeed and overspeed protection is required in addition to an analog output to a chart recorder. The optimum speed of the web is 1100 FPM. The absolute maximum speed equals 120% of the optimum speed and the absolute minimum speed equals 70% of the optimum speed. If the web speed exceeds these limits, the appropriate alarm will latch and shut-down the machine. The "on" delay feature is used for both setpoints to allow the textile machine five seconds to reach operating speed during start-up and also allow for temporary over or underspeed situations. The analog output will monitor the efficiency and provide 4 mA @ 0.00% and 20 mA @ 120.00%. A proximity sensor is used to sense a key-way on an idler roll and produces 565 Hz @ 1100 FPM. Reset of the latched alarms and peak/valley buffers is accomplished via a key switch connected to inputs E1-CON and E2-CON.

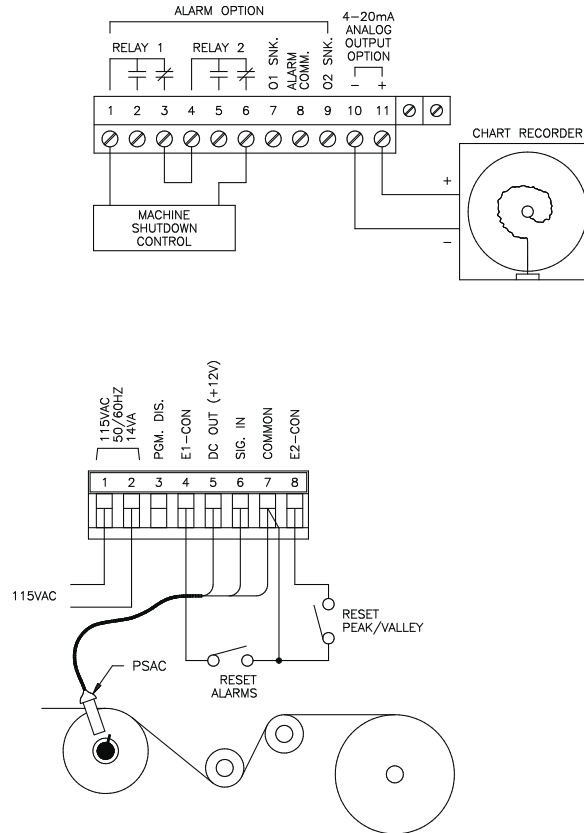

## ORDERING INFORMATION

MODEL NO.	DESCRIPTION	OPTIONS			PART NUMBERS FOR AVAILABLE SUPPLY VOLTAGES	
		DUAL ALARM	SERIAL COMMUNICATIONS	ANALOG OUTPUT	*10 to 30 VDC	115/230 VAC
IMI	Intelligent Digital Rate Meter	NO	NO	NO	IMI04130	IMI04160
		NO	YES	NO	IMI04131	IMI04161
		YES	NO	NO	IMI04132	IMI04162
		NO	NO	4 to 20 mA	IMI04133	IMI04163
		YES	YES	4 to 20 mA	IMI04137	IMI04167
		YES	YES	0 to 10 VDC	IMI04139	IMI04169

For more information on Pricing, Enclosures & Panel Mount Kits refer to the RLC Catalog or contact your local RLC distributor.

\* Note: The 10 to 30 VDC versions of the IMI have not been specified for EMC.